

CARDINIA SHIRE COUNCIL

Public Toilet Strategy

2020 - 2030

1	PART A – OVERVIEW	2
1.1	Purpose and Need	2
1.2	What Should the Strategy Provide	2
1.3	What is a Public Toilet	3
1.4	Defined Goals of this Strategy	3
1.5	Definitions	3
2	PART B – BACKGROUND	4
2.1	Current Situation	4
2.2	General Principles for Ongoing Provision and Management of Public Toilets	5
2.3	The Role of Council	8
2.4	Key Documents and Areas of Inference	8
2.5	Toilet Typology	12
2.6	Changing Places Facilities	14
3	PART C – CONSIDERATIONS	15
3.1	Key Issues and Challenges	15
4	PART D - LIFE-CYCLE PLANNING AND ACTIONS	15
5	PART E – PUBLIC TOILETS DATA AND REFERENCES	16
5.1	Details of Public Toilets	16
5.2	Public Toilets by Ward and Type	17
5.3	Locality Map of Public Toilets	18
5.4	General List of Public Toilets	19
5.5	Summary Condition Rating Data	20
5.6	Planning and Budgeting Data	21
5.7	Community Consultation – What we have heard	23
5.8	Pictures and Line Diagrams of Existing Public Toilets	43
5.9	Capital Improvement Plan	107
5.10	References	107

1 PART A – OVERVIEW

1.1 Purpose and Need

Council is committed to creating a liveable Shire that provides high quality facilities for the community and visitors. A class of assets that contribute to a liveable Shire are public toilets. Safe, clean and accessible public toilets at appropriate locations, make a practical difference in encouraging visitors and residents to spend time at and enjoy the diverse public spaces and facilities provided as part of the Shire's tourism and urban infrastructure.

The Cardinia Shire Council has embarked in developing a Public Toilet Strategy, to better understand and improve the service level requirements that need to be provided from public toilets, address ongoing community and visitor expectations, as well as aligning with the current Council Plan key strategic objectives:

- Our People
 - a. Access to a variety of services for all.
 - b. Increased awareness of safety.
- Our Community
 - a. Our diverse community requirements met.
 - b. Increased levels of community participation.
- Our Environment
 - a. Provision and maintenance of assets on a life-cycle basis.
 - b. Enhanced natural environment.
 - c. Natural and built environments supporting the improved health and wellbeing of our communities.
- Our Governance
 - a. Long-term financial sustainability.

A strategic approach for these assets will:

- Deliver a relevant asset management plan that appropriately manages and focuses on high demand public facilities – public toilets.
- Ensure an equitable provision of public toilets that supports a diversity of users throughout the Shire.
- Guide the development and implementation plan that supports the provision of safe, clean and accessible public toilets for new or existing facilities.
- Support active lifestyles throughout the Shire, including walking, jogging, cycling and other open space and recreational activities.
- Give direction for the consideration and implementation of Changing Places facilities.
- Assist in the decision-making of placing public toilet facilities in the Shire.

1.2 What Should the Strategy Provide

The Strategy will provide:

- Up to date data on the management, condition, location, and type of public toilet facilities.
- The relationship of public toilets in the landscape, e.g. at shopping strips, on reserves, and surrounding areas.
- References and in support of Council Plan, strategies, and policies. For example, the Open Space Management Framework, Building Maintenance Policy, Pedestrian & Bicycle Strategy, Liveability Plan, Safer Community Strategy, Local Government Act, etc.
- A 10-year financial framework for Council in providing safe, clean, accessible, and appropriate public toilets for locals and visitors. It will take into consideration location, security, design, usage levels and associated life-cycle costs.
- Guidance on design and build considerations for such facilities to positively impact on efficiency in usability, availability, cleanliness, and environmental management of power and water.

1.3 What is a Public Toilet

Generally, a public toilet may be defined as any toilet that can be used by any member of the public for their use.

For Council, public toilets are defined as ‘free-standing or attached public facilities, which are wholly operated and managed by Council, and include such things as regular maintenance and cleaning activities, opening and closing of facilities, etc.’

Such facilities do not include toilets that may be free-standing or attached to other facilities located on reserves, or other land and where managed by a user group, community committee, or under a Council – user arrangement.

1.4 Defined Goals of this Strategy

A number of goals have been identified to support and achieve the requirements of this Strategy as follows:

- All public toilets will be maintained and cleaned to a set standard that will meet Council and community expectations.
- All existing public toilets will be progressively updated through a planned and ongoing approach, to meet and sustain required regulatory and accessibility requirements.
- New public toilets will be designed to meet community expectations, including giving consideration to Changing Places facilities.
- New public toilets will be provided in accordance with the requirements of the Open Space Management Framework, and will consider demonstrated community needs, demand and levels of service.

1.5 Definitions

Accessibility

A level of service, which considers how compliant an existing public toilet is with the Disability Discrimination Act and the Council’s Enhanced Standard – Universal Design.

Performance/Standards

A measure of the condition, comfort, functionality and capacity, of an existing public toilet in comparison to required performance and standards.

Activity Groups

Users of public toilets who have different characteristics and issues that need to be considered when evaluating the need and requirement for a public toilet.

ESD

Refers to the Council’s Enhanced Standard Sustainable Buildings and associated Environmentally Sustainable Design standards.

NCC

Refers to the National Construction Code requirements needing to be achieved.

AS

Refers to the applicable Australian Standard.

DDA

Refers to the current Disability Discrimination Act and relevant regulatory framework in addressing minimal requirements for providing accessibility and use of facilities by persons with disabilities.

CPTED

Refers to the Crime Prevention Through Environmental Design principles and in draft CPTED strategy currently being developed. The application of CPTED principles to existing and new facilities means that the design of facilities or public spaces will minimise or remove the likelihood of poor behaviour and criminal activity.

Changing Places facility

Provide suitable facilities for people who cannot use standard accessible toilets. Changing Places are accredited facilities to meet design standards. Features of a changing Places facility are: larger than standard accessible toilets with adult-sized change tables and tracking hoists to meet the needs of people with high support needs.

2 PART B – BACKGROUND

2.1 Current Situation

The Shire currently manages a total of 35 public toilets, with the first being built in Garfield Recreation Reserve in 1952. Historically, toilets appear to have been provided in an ad-hoc manner, consisting of a mix of Council-constructed/delivered facilities and toilets built by community groups on Council land, which were added to Council's asset register. Toilets were built to comply with the relevant compliance requirements and standards of the time, many of which have been superseded.

Generally speaking, most public toilets are in good structural condition, with Council having addressed major defects over time.

The asset stock consists of freestanding or attached structures built in various materials such as timber, brick and concrete.

The toilets have generally performed to reasonable needs over time. A number of the toilets currently do not comply with modern accessibility and CPTED standards and refitting them to comply may not always be possible.

There are also a number of pre-fabricated automated facilities, which have been popular in Australia during this time. These have been maintained to reasonable standards, through specialised contracted arrangements, and where necessary, such as at Beaconsfield, have been updated accordingly.

With reference to vandalism, over the last 4 years, approx. \$40k of vandalism costs have been experienced across all public toilets. Prime incidents have occurred at KWR, Pakenham and Lang Lang.

These township do have the most public toilets with Emerald coming 4th. Vandalism trends however are difficult to identify and there appears to be a spike with events generally during school holidays.

Graffiti extent and costs at this stage are hard to articulate, as these form part of a broader risk mitigation approach, covered by the Operations Graffiti Team.

Another significant cost impact is blockages, which may be attributed to lack of sanitary bins.

As with reference to expenditure related to Reactive and Routine Maintenance costs associated with Public Toilets they are as follows:

- Reactive Maintenance: \$ 82,158.07.
- Routine Maintenance: \$192,116.40.

2.2 General Principles for Ongoing Provision and Management of Public Toilets

The following General Principles underpin the goals needing to be met in this Strategy and provide support to the ongoing provision and management of public toilets:

2.2.1 Provision

The provision of public toilets will be prioritised on Council owned and managed land, giving consideration and as informed by the Open Space Management Framework.

However, Council will also give additional consideration, where a proposal by community will achieve net community benefits and outcomes are aligned with the intent of this Strategy. For example, an external funded opportunity and collaboration project with the community and demonstrated evidence of need for such facilities.

2.2.2 Cleanliness

Cleanliness is an abstract state of being clean and free from germs, foreign matter, dirt, trash, or waste and the habit of achieving and maintaining that state. Also, ensuring that items such as toilet paper, liquid soap and paper towels, where provided, are continuously and adequately stocked and maintained. The public toilet network will be maintained and serviced so that the community perceives or experiences them to be fit for purpose and adequately cleaned.

It will include a service level program that ensures toilets are maintained to a specified standard and will ensure that very few complaints are received regarding the cleanliness or maintenance of public toilets. Appropriately planned cleaning and maintenance activities, in accordance with Council service level requirements and community expectations, will ensure hygiene and required presentation to users of such facilities.

2.2.3 Investment Priority and Community Benefit

Public expectations and needs, whether for existing or new, will always be considered, in conjunction with the reasonable requirements of such facilities, demonstrated community proposals, practicalities of such provision with determined priorities, expenditure program and funding opportunities.

2.2.4 Availability

Public toilets should be:

- Provided in public spaces where residents spend extended periods of time or where high volumes of visitors to the region spend time.
- Located where the public (including residents and visitors) will generally stay for longer than two hours. This includes activity centres, significant tourist destinations and major parks.
- Provided at strategic locations for major walking and cycling routes. Provided at “destination” parks, such as outdoor recreation areas where travel is required and no other facilities are in the area.
- Located in public open space areas, which contain 'activity generators' such as BBQ facilities, regional play spaces, large picnic areas etc.

2.2.5 Asset Condition and Rating

Is a measure that brings about the factors of age, the impacts from the environment, maintenance history, treatment by users, and how much the asset is used, in order to understand on the spectrum of 1 to 5, whether the facility can continue to provide the service through the application of appropriate rectifications or may have reached its useful life.

2.2.6 Safety

Safety is a measure of the safety of the facility in terms of its physical location, lighting, opportunities for concealment, and measure of natural surveillance. The safety requirements of the community will be prioritised over other decision-making considerations and informed from the Community Safety Strategy and guidelines.

The provision of all public toilets must be safe and inviting to use for all members of the community. Public toilet facilities must be clean and functional, and presentation should ensure that the users feel the facility is safe to use. Public toilets should be located in visible positions, so they are easy to identify within the surrounding public space and maximise casual surveillance. In line with accepted CPTED principles, public toilets should be well lit for the expected use profile, using passive and active lighting both internally and externally. Public toilets should be accessible to all users and provide for special needs such as mobility challenges and parents with prams.

2.2.7 Accessibility

Accessibility is a measure of how accessible the facility is for people with disabilities including availability of parking for the disabled, and the compliance of the facility with current regulatory requirements and Council's Enhanced Standard – Universal Design. Public Toilets shall be accessible to everyone and well connected to pedestrian areas and public transport.

Public toilets shall comply with at least the current Disability Discrimination Act and consider the need for Changing Places facilities as referenced in section 2.7.

2.2.8 Environmental Sustainability

The environmental impacts of public toilets should be minimised. Key environmental impacts from public toilets are related to water and energy consumption. The environmental sustainability of Council public toilets will be improved through the provision of new and refurbished public toilets incorporating the requirements of Council's Enhanced Standard - Sustainable Buildings.

Various sustainability improvements have already been made to public toilets, including rainwater harvesting installation, occupancy sensor installation for lights and exhaust fans, the provision of water efficient appliances and energy efficient lighting.

Opportunities to procure renewable energy for public toilets' energy needs will also be explored. The efficiency of toilets will continue to be monitored through analysis of billing data and usage patterns.

2.2.9 Awareness

Residents and visitors should be aware of the location of public toilets and can find them easily at all public spaces. Up to date information on public toilet locations should be available on multiple digital platforms and contained in printed guides and maps.

Within any specific precinct or location, wayfinding and locational signage or visual cues (such as recognisable building design and colour) should be available, making it easy to find public toilets and in identifying accessible cubicles.

Perception of the region's public toilet infrastructure should also be as such that they are being well used and appreciated.

Further, that community feedback demonstrates high satisfaction with extent of provision of public toilets. Lastly that the national public toilet map is being continually updated.

2.2.10 Identifying Demand for New Public Toilet Facilities

In conjunction with the considerations from Section 2.5 Key Documents and Areas of Reference, for a new facility to be considered, it needs to satisfy one or more of the following criteria:

- Located in a busy or high-profile node (e.g. Activity Centre or Transport Hub), or a location of high demand generally (for example open space, recreation areas).
- Where there is demand for a new facility, identified through community engagement.
- The location of an existing toilet is not appropriate from a Crime Prevention Through Environmental Design (CPTED) perspective or is otherwise considered 'unsafe'.
- An existing facility is not considered to be accessible within the meaning of the current Disability Discrimination Act (DDA), and is unable to be suitably upgraded.
- A lack of public toilets encourages undesirable antisocial behaviour (e.g. public urination/defecation, etc.).

2.2.11 Replacing or Refurbishing an Existing Toilet

The following key directions should be considered when deciding to refurbish or replace a public toilet in the same (or similar) location.

Determining a high level of demonstrated community need is the first step in evaluating whether a public toilet should be replaced or refurbished in the same location. Following the determination of this need, a range of other directions should be considered as outlined below.

KEY DIRECTIONS

- **Demonstrated Community**

Is there a demonstrated community need for the replacement or refurbishment of an existing public toilet?

There must be a high level of demonstrated community need to warrant the replacement or refurbishment of an existing public toilet, unless it is unsafe to use or may be non-compliant with the requirements at the time of construction.

Demonstrated community need means that there is a quantum of evidence from the community or from Council's knowledge of the community, that an existing facility is not adequately functioning and does not meet the majority of the General Principles outlined in the Strategy. If it can be proven that a demonstrated community need for the replacement or refurbishment of an existing toilet is evident, the following secondary considerations should be taken into account. Upon the evaluation of the General Principles, the existing Long Term Financial Plan, annual and ongoing financial allocations and the other considerations, as identified here-following, then the replacement or refurbishment of an existing public toilet may be considered.

- **Is the existing public toilet in poor condition?**

The condition of a public toilet is considered poor when the following apply:

- There is a high presence of vandalism or graffiti;
- Facilities are unhygienic and difficult to maintain/clean;
- There are obvious signs of wear on the existing facilities within the toilet;
- Features within the toilet do not work (for example, door locks, taps or flushing mechanisms);
- There are issues with odour or presence of vermin;
- Environment/facilities are unsafe or dangerous with respect to CPTED principles (Council Officers should also refer to building condition audits).

- **Does the existing toilet have a low level of usage?**

Levels of usage can be determined analytically or from empirical observations. Research counts can be conducted to provide a good basis for understanding the levels of patronage to a particular facility.

Levels of usage can also be observed through discussions with cleaning contractors, local business owners, community groups or discussions with particular segments of the community. If an existing public toilet has a proven level of low usage, the removal of the facility may be more appropriate. Alternatively, a different location within the same area may encourage higher usage.

- **Is there an appropriate gender provision within the facility?**

In certain locations, anecdotal evidence or community feedback may suggest that some toilets are more frequented by a particular gender. In this instance, Council may consider providing additional capacity as required.

Gender neutral toilets may also be appropriate for basic or standard toilet types.

Refurbishment of toilets which do not adequately provide for all genders should be considered in first instance, rather than removal.

- **Are there issues with ongoing anti-social behaviour?**

Anti-social behaviour includes a range of undesirable activities such as vandalism, loitering, sexual or drug related activity or violence.

Interventions through CPTED can improve the safety of public toilets to a certain extent. However, facilities which are poorly sited and have no reference to the public realm present a range of challenges.

- **Does the toilet have appropriate facilities for the location?**

The type of facilities and internal design features will vary depending on the context and the location in which the public toilet is sited. Examples include the provision of hand dryers and baby change tables. Results from the community consultation will provide some guidance to inform the desired provision of such facilities.

- **Does the existing toilet meet the requirements of the General Principles?**

Before a public toilet is recommended for replacement or refurbishment, its function should be assessed against the General Principles. If an existing facility cannot be retrofitted to meet these General Principles, then its removal should be considered.

2.3 The Role of Council

Cardinia Shire Council is committed to fulfilling the social and corporate requirements in supporting the health, wellbeing and community vitality of its community and visitors. The Shire recognises and acknowledges public toilets as critical infrastructure, in supporting and augmenting physical, recreational, and similar associated activities in public spaces, and will ensure that these assets perform according to required service levels.

2.4 Key Documents and Areas of Inference

There are a number of critical areas that inform on the development and continued management of our public toilets listed hereunder.

2.4.1 Open Space Management Framework

The Open Space Management Framework (OSMF) recognises the importance of open space for wellbeing and biodiversity; establishes a vision for open space; provides for an open space hierarchy (e.g. Regional, Municipal, District, Neighbourhood and Local); documents current legislative documents, organisational responsibilities, strategic and policy directions, and community needs and expectations; considers open space through different lenses and perspectives (e.g. People and Community, Environment, Development, Assets); and provides for an action plan to drive the improvement of open space into the future.

Developer and community expectations of what open space should include are ever increasing.

With this in mind, whilst a long term action plan is being formulated through the new Strategy, there are initial potential opportunities for consideration:

a. Activity Centres

Some public toilet facilities are located in Activity Centres to help support the function of the Centre. The availability of safe, clean and accessible public toilet facilities promotes and enhances the prosperity of Activity Centres and extends the amount of time that visitors are able to stay. Activity Centres include retail business centres as well as a mix of business, community and other uses.

Those with regional catchments are destination centres, which may be served by multiple transport routes and may consist of entertainment venues, offices, commercial activities, community and governance functions. Smaller catchments have a more local community focus and are usually mixed use.

Where access to a public toilet cannot be guaranteed, it is recommended that Council work with local land owners and businesses to enable where practicable public access. For example, Beaconsfield shopping complex.

b. Sporting Grounds

Sporting grounds have toilet facilities, which at times are externally accessible attached to existing pavilion buildings or may be standalone toilet facilities. Currently many of these facilities are only open when there are events programmed. As such, working with clubs, committees may provide an opportunity to collaborate in providing broader public use of such toilet facilities. Further, and as part of the Capital Works Program considerations, upgrade or new pavilions will consider the availability of accessible public toilet facilities as part of the works. For example, Pepi's Land pavilion.

c. OSMF on Assets

'Parks, reserves, linear connections, streetscapes and private and government owned spaces, all contribute to the Shire's open space network and natural environment. Not all spaces can provide everything for everyone, or receive a full range of services, infrastructure and development. For example, BBQ's, public toilets, play spaces, sports facilities. Infrastructure provision and service levels need to be appropriate to the location, level of use and required standards, as identified by the hierarchy classification. Equity of access to Council resources needs to be considered in planning and development of open space across Council.'

'Traditionally open space has been viewed as a community asset provided at no cost to users. However, changing community expectations and political and legislative environments are presenting a challenge for Council. Infrastructure needs to be managed wisely, based on service requirements and long term financial viability, adopting an asset lifecycle management approach to maximise value.'

The provision of public toilet facilities will continue to be assessed by Council alongside the community to establish requirements and inform the Long Term Financial Plan.

2.4.2 Cardinia Shire's Liveability Plan; Municipal Public Health and Wellbeing Plan (MPWHP)

Council's Liveability Plan 2017–29 interlinks with the Open Space Management Framework and recognises Council's role in coordinating local public health planning, by bringing together a range of organisations and local groups to collectively protect, improve and promote the health and wellbeing of all Cardinia Shire residents. A Partnership Steering Group of 20 organisations, and extensive community consultation, has supported the development of this Plan.

The shared vision of the Plan is:

'Cardinia Shire is a liveable, resilient community where the environment flourishes and residents are healthy, included and connected.'

'According to Melbourne University's School of Place, Health and Liveability, liveable communities are regarded as safe, attractive, socially cohesive and inclusive, and environmentally sustainable with affordable housing linked via public transport, walking and cycling to employment, education, public open space, local shops, health and community services, and leisure and cultural opportunities.'

Based on community consultation and research, the Plan provides clear guidance for collectively addressing our community's health and wellbeing needs and aspirations over the next 9 years. The document provides a framework for public health planning within the Shire.

Key focus areas include:

- Improved mental health and wellbeing;
- Improved social cohesion;
- Improved safety;
- Reduced family violence;
- Reduced obesity;
- Reduced harm from tobacco, alcohol, drugs and gambling;
- Reduced financial vulnerability.

In particular the Plan's medium term outcomes are:

- An increase in people walking and cycling for transport;
- An increase in participation in local education;
- An increase in participation in local employment;
- An increase in access to affordable, nutritious food;
- An increase in access to services and social support close to home;
- An increase in access to appropriate and affordable housing;
- An increase in participation in open spaces and places.

From the Liveability Plan 'open spaces and places are strategically planned, developed and maintained to create a sense of place, encourage participation, protect the natural environment and promote health and wellbeing. In the medium term we expect to see an increase in participation in open spaces and places.

This will be achieved by:

- Strategically planning and maintaining open spaces and places to be safe, accessible, appealing and connected.
- Enriching local identity and place making through public art and cultural expression.
- Increasing access to leisure, *sport and recreation opportunities*.
- Protecting and enhancing the environmental quality of open spaces and places.'

2.4.3 Community Safety

A safe community is not just one that is free of crime, violence and anti-social behaviour; it is one that focuses on creating a safer community at all levels, within all areas.

Cardinia Shire has a long-standing commitment to community safety and crime prevention and in 2014 Cardinia Shire made the commitment to develop a more coordinated and structured approach to creating safer communities and agreed to begin the process of designation as an International Safe Community through the World Health Organisation.

At the same time, a decision was made to move away from the term 'community safety' to 'safer communities' so that an all-encompassing, proactive approach was ensured.

The International Safe Communities model is an internationally recognised, evidence based, best practice model premised on collaboration, partnerships and community capacity building to reduce injury and enhance safety. The model recognises that no community can ever be deemed completely safe, however it embraces the notion that a community can be made safer through collective efforts with and between the community and service sector.

The World Health Organisation's International Safe Communities model provides a framework, which was used to develop a strategic direction and achieve Council's accreditation as an International Safe Community, being the fourth International Safe Community in Metropolitan Melbourne and the fifth in Victoria.

Only a small number of communities/municipalities across Australia have achieved designation as an International Safe Community.

A safe community is not just one that is free of crime, violence and anti-social behaviour; it is one that focuses on creating a safer community at all levels, within all areas. Community safety affects every member of the community and requires all residents and organisations alike to work in partnership to create safer environments.

Building a safe community is multifaceted and requires a coordinated, whole of community approach, in order to respond effectively to local and regional issues. The formation of strong partnerships between a wide range of Government and community services are critical to achieving outcomes that contribute to a connected, safe and empowered community.

The Cardinia Safer Communities Strategy has been developed to provide the framework for the implementation of solutions that aim to improve safety and perceptions of safety across the six priority focus areas within Cardinia Shire as follows:

- Road, pedestrian and transport related issues.
- Alcohol and other drugs.
- Mental health related issues.
- Crime.
- Family violence.
- Emergency management.

The Cardinia Safer Communities Strategy is being implemented by the Cardinia Safer Communities Partnership Committee and assisted through the establishment of multi-disciplinary Action Groups. These Groups are responsible for developing action plans for their particular priority area of focus.

The Cardinia Safer Communities Strategy identifies Council's commitment to a Safe Community. There is an expectation that each individual person working, visiting or living in the Shire will take shared responsibility for their personal safety. Where this is not possible, key agencies across the municipality will endeavour to support their safety through action plans that identify high risk populations and environments.

These populations are defined as those, which may be vulnerable due to a particular defining characteristic leading to an increased risk of injury or victimisation. Priority populations may include children, young people, older people, people with a disability, low income earners, culturally & linguistically diverse (CALD) and Indigenous communities.

The Council Plan sets out Cardinia Shire Council's strategic vision and outlines Council's commitment to the community, key priorities and anticipated challenges over a four year period. The Council Plan outlines five key strategic objectives. Under the strategic objective of Our People, action six is directly related to community safety:

- Increased awareness of safety;
- Work with the police, State Government and community to improve safety in homes, businesses, public places and roads;
- Improve awareness of township safety.

The Municipal Public Health and Wellbeing Plan (MPHWP) takes into consideration all aspects of Cardinia Shire's environment and how these impact on the community's health and wellbeing. The MPHWP outlines four domains with a set of priority issues and actions under each. The four areas are Our People, Our Community, Our Environment and Our Economy. This work is reflected in the Council Plan Our Community.

Cardinia Shire Council has a variety of other policies that have implications and relevance for community safety. Key policies and plans include:

- Road Safety Strategy.
- Bicycle and Pedestrian Strategy.
- Reconciliation Action Plan.
- Cardinia's Access and Inclusion, Disability Action Plan.
- Positive Ageing Strategy and Action Plan.
- Risk management framework and policy.
- Injury management policy.
- Gender Equity Framework.
- Communities That Care Cardinia Action Plan.
- Cardinia Municipal Emergency Management Plan.
- Youth Strategy.

2.4.4 Local Government Act

The **Local Government Act 1989** states that the function of a Council should include planning for and providing and maintaining services and facilities to best meet the needs of the local community and ensuring that these facilities are accessible and equitable.

2.5 Toilet Typology

2.5.1 Siting

Public toilets in Cardinia Shire have been located in a variety of ways, are highly visible from the streetscape and are generally positioned to maximise sight lines to the public toilets from attractions, such as playgrounds, BBQ areas, and seating areas. This encourages passive surveillance of public toilet facilities, which can enhance perceptions of personal safety for many users. Visibility to public toilets can be impaired by things such as overgrown vegetation or structures such as walls and signage or placement with existing buildings. Cardinia Shire's public toilets are also sited adjacent to car parking areas. In these situations, public toilets are not integrated into the streetscape or sited within a landscaped setting.

Often they are orientated toward the car parking area and are accessible by a path. Public toilets located within activity centres are generally located in busy areas with high foot traffic, where as in parks or recreational space they are in close proximity to playgrounds or picnic facilities.

2.5.2 Design and Type

There are a range of public toilet types in Cardinia Shire, including the 'traditionally built' toilet block and automated Exeloo facilities. The established stock of toilets are generally in a fair to good condition. The existing stock of public toilets in Cardinia Shire comprises of facilities constructed over a long period of time. Of the older toilet blocks that have not been renovated, many are not compliant with current accessibility requirements or accessible for all abilities. There is an expectation that over time, all public toilets in Cardinia Shire should be at least NCC and DDA compliant and to the Council's Enhanced Standard Universal Design.

Public toilets generally open out onto the street or public space, in some locations offering facilities for people with disability, but in general have separate gender banks of male and female toilets. The internal fit-out of toilets is generally very simple with minimal design treatments to the interior of toilets. Toilets generally include hand basins, sharps disposal, a mirror, natural/artificial lighting, soap dispensers and a way for our community to continually provide feedback or in reporting to Council on condition and other requirements when using public toilets.

2.5.3 Freestanding Public Toilets

These toilets predominantly supply basic services of male and female cubicles, male urinals, washbasins, stainless steel mirrors. Many of these toilets do not have access to facilities for the disable, may contain a baby change table, and may not always be lockable due to the absence of entry doors or gates.



000368 Lang Lang Jetty Lane



000341 Garfield Ritche Street

2.5.4 Freestanding Automated

These toilets are fully automated with all services available to all users and provide additional facilities of automated door opening and locking, syringe disposal bins, baby change table, self-cleansing function and non-slip flooring. In general, after a ten minutes warning sound, the door automatically opens for safety.



109089 Pakenham Bourke Park Exeloo



024543 Beaconsfield Exeloo

2.5.5 Freestanding Reserve Toilets

These toilets range in design, with most being basic brick, sometimes containing a cubicle providing facilities for the disabled, a baby change table, and may be serviced by water tank supply. These may not be lockable due to the absence of entry doors or gates.



000344 Garfield Recreation Reserve



000431 Nar Nar Goon Recreation Reserve



023609 Emerald Puffing Billy Place

2.6 Changing Places Facilities

Standard accessible toilets may meet the needs of people with disabilities. However, there are those that require and need personal assistance to use the toilet or change continence pads, including people with profound and multiple learning disabilities, spinal injuries and people living with stroke. Without such appropriate facilities, carers are forced to change continence pads on public toilet floors or wait until they go home. This is unhygienic, undignified and unacceptable. This is where a Changing Places facility offers a solution. These accredited facilities are larger and are provided with the appropriate equipment, including a changing table and hoist designed to support people with disabilities and who need assistance.

Absence of such facilities means that people with disabilities are unable to participate fully in civic life and may result in harm to their health and wellbeing.

Changing Places facilities are designed for people who have additional requirements not provided by standard accessible toilets. A Changing Places facility in general must include:

- Height adjustable, adult sized changing bench;
- Ceiling track hoist system;
- Adequate space for the disabled person and up to two assistants;
- Centrally located toilet with space both sides for assistants;
- Privacy screen;
- Wide paper roll;
- Large waste disposal bin;
- Washbasin, preferably height adjustable.

In 2019, Australia became the first country to regulate for public toilets based on the Changing Places design. As of 1 May 2019, the regulatory framework referenced the Changing Places design standards requiring one unisex Accessible Adult Change Facility to be provided in some classes of occupancy like shopping centres, museums and art galleries, sports and entertainment venues and airports. Toilets built according to the Changing Places design standards will generally meet the Deemed-to-Satisfy provisions of the NCC.

Typically Changing Places facilities are provided in locations where large numbers of people may visit and where people may attend for several hours at a time (e.g. between 3 to 4 hours).

Currently Cardinia Shire Council has one accredited Changing Places facility located at the Deep Creek Reserve, which has been fully funded by Council as part of the Reserve redevelopment completed in 2019 – 2020 financial year.

In furthering the consideration, planning and location of Changing Places facilities at Cardinia Shire, together with fulfilling and aligning with the Council Plan strategic objectives and general principles, a model approach has been developed as follows:

- a. A community engagement plan will be designed in consultation with the Cardinia Access and Inclusion Advisory Committee (CAIAC) and the Communications Unit to equitably assess across Shire needs for Changing Places facilities.
- b. The consortium of stakeholders for the community engagement should include residents with a disability, carers, local disability and health service providers, the general community and staff.
- c. The feedback received will help to understand better the required needs, how Council should be considering and prioritising Changing Places facilities, in order to remove barriers that people with disability face.
- d. The identified priorities will be included in the Long Term Financial Plan, and where appropriate funding from Government sources, where practicable, will be sourced to support the realisation of such facilities.

3 PART C – CONSIDERATIONS

3.1 Key Issues and Challenges

Our existing public toilet facilities have various concerns such as not being well maintained; are ageing and due to their construction date are not up to today's standards with reference to an 'all inclusive' facility; require safety measures upgrades; do not altogether consider sustainable measures like LED lighting; do not consider where hoists or changing tables for adults should be provided; have inconsistent opening and closing times, with some of these facilities not having any external doors or gates; and are susceptible to a level of vandalism or graffiti and anti-social behaviour from time to time.

An independent assessment has been carried out considering condition status and rating, including safety and cleanliness. The rating assessment provides a ranking between 1 and 5 applied for each public toilet – e.g. where a higher ranking indicates a priority for renewal and a lower ranking meaning that the facility is performing adequately and requires no immediate improvement work.

4 PART D - LIFE-CYCLE PLANNING AND ACTIONS

In December 2019, our maintenance contractor, as part of the Facility Management and Maintenance Contract requirements, began the Condition and Rating Assessment of the public toilets across the Shire. This work was completed in January 2020 with interim results as considerations for current and future planning including budgeting requirements.

Whilst the Condition Assessment identified public toilet facilities with elements in most need of repair, renovation or improvement, the Rating Assessment provided an overall status on whether such facilities should be considered for renewal or potentially have no requirements for immediate improvement work.

Further, each time a public toilet is cleaned and as part of the current Cleaning and Internal Waste Contract, daily and weekly assessments are carried out with any damage, vandalism, graffiti or required repairs reported to Council for ongoing action.

5.2 Public Toilets by Ward and Type

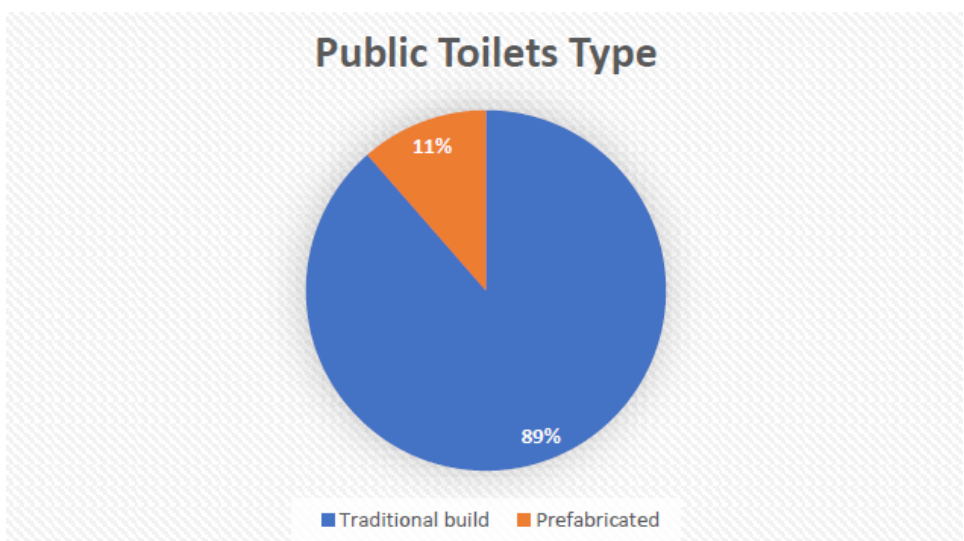
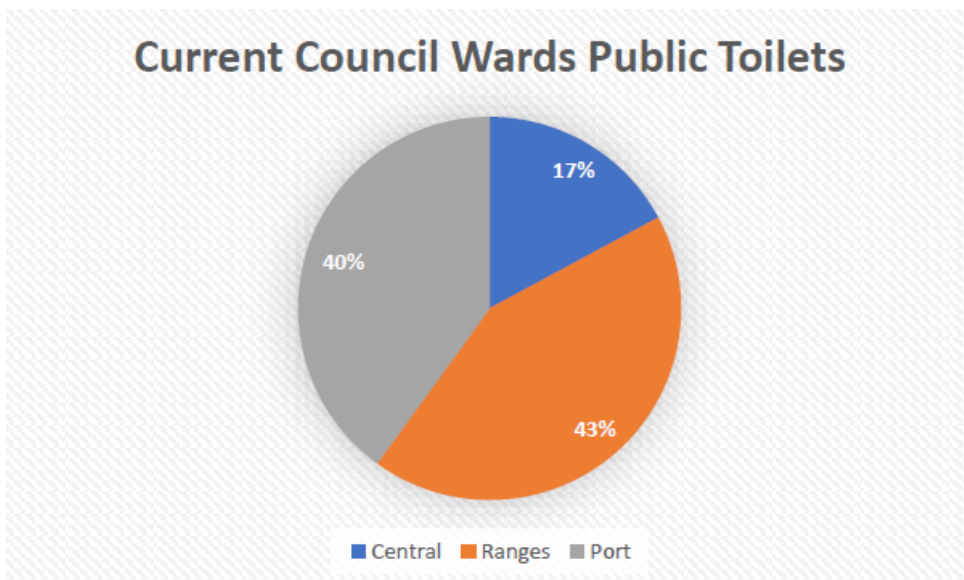
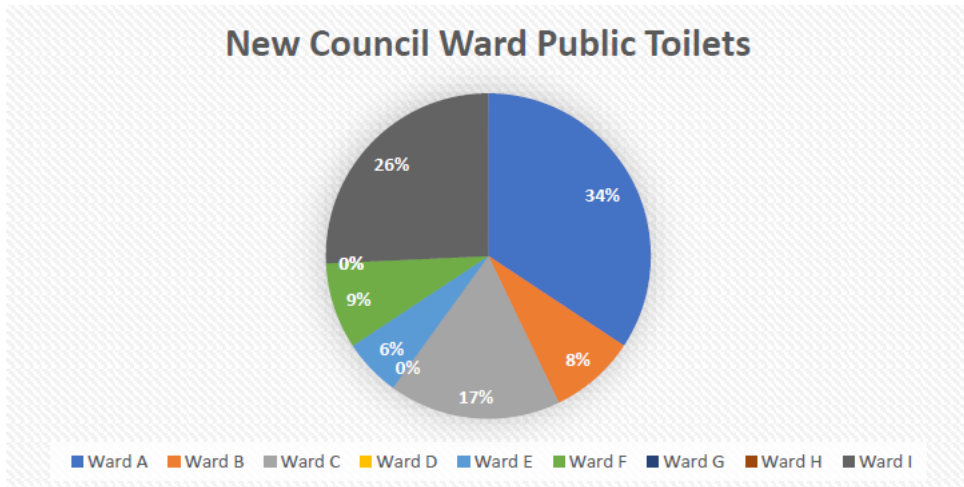

5.3 Locality Map of Public Toilets

(e.g. red dot with asset # should be referenced to foregoing List)

Council Managed Public Toilets

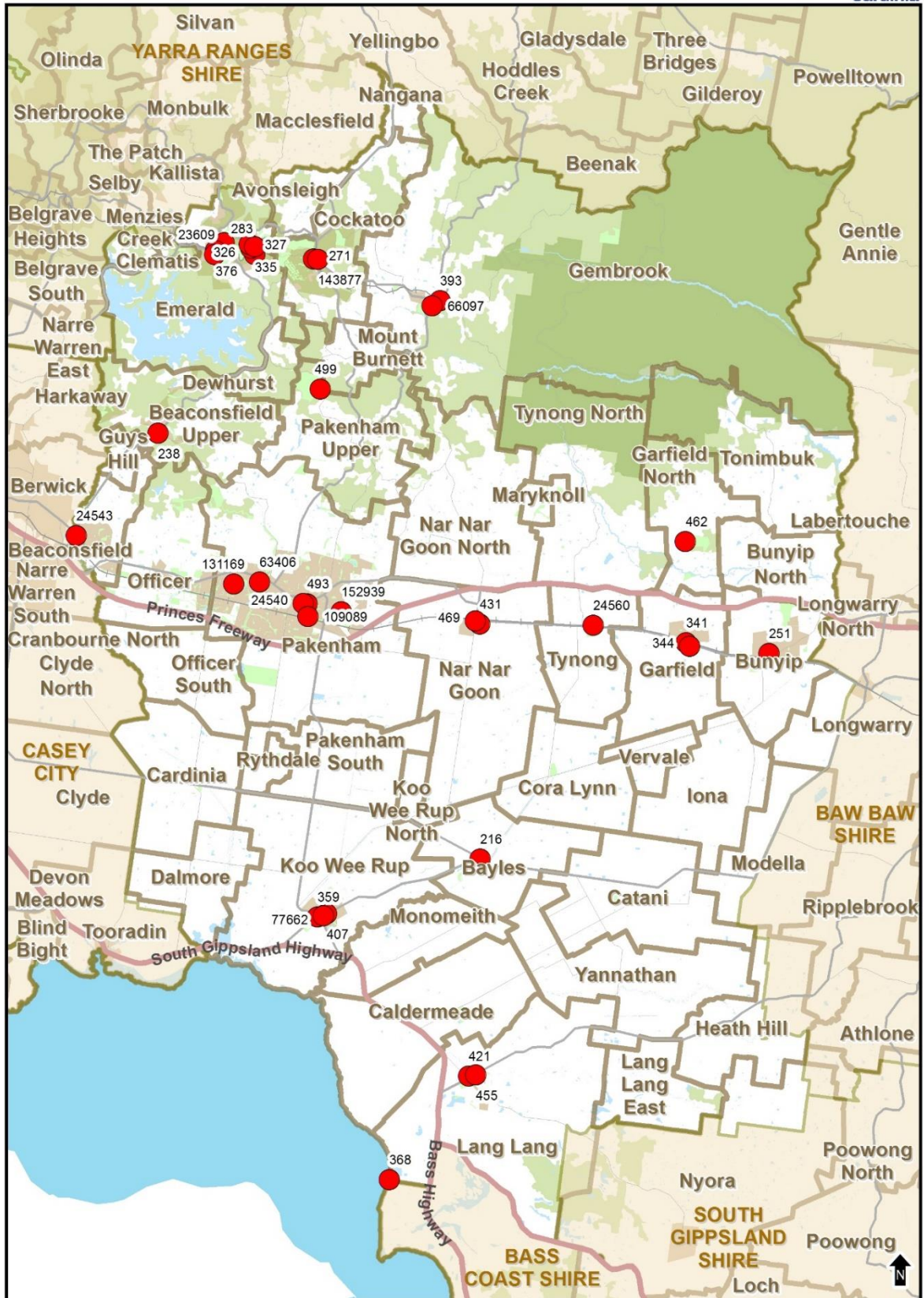

Printed: 21-May-20 Data Source: State & Local Government. © CARDINIA SHIRE COUNCIL

5.4 General List of Public Toilets

Asset #	Township	Site
216	Bayles	664 Koo Wee Rup Road
24543	Beaconsfield	Princes Hwy Exeloo
238	Beaconsfield Upper	Charing Cross Emerald Beaconsfield Road
251	Bunyip	Main Street
143877	Cockatoo	Exeloo
271	Cockatoo	McBride Street
23609	Emerald	Puffing Bill Place - Kilvington Drive
375	Emerald	Belgrave -Gembrook Road (Near Library)
280	Emerald	Museum
376	Emerald	Ferris Road
327	Emerald	ELP NW side of Lake Treganowan
326	Emerald	ELP Toilets, Showers & Change Area west of cafe
325	Emerald	ELP east of Lake Nobelius
283	Emerald	ELP located behind kiosk
335	Emerald	ELP Public Toilets next to Lions Den shelter
341	Garfield	Ritche Street
344	Garfield	Recreation Reserve Toilet Block
462	Garfield North	Mt Cannibal
393	Gembrook	Cnr Beemak East and Gembrook Road
66097	Gembrook	Redwood Road
77662	Koo Wee Rup	Bus Terminal Public Toilets, 345 Rossiter Rd
407	Koo Wee Rup	310 Rossiter Road
359	Koo Wee Rup	External Pool Toilets - Rossiter Road
421	Lang Lang	Kester Kitchin Park
368	Lang Lang	Jetty Lane and Foreshore Rd
455	Lang Lang	Tennis Club, 3 Roseberry Street
469	Nar Nar Goon	Main Street
431	Nar Nar Goon	Rec Reserve Toilets - Spencer Street
109089	Pakenham	Bourke Park
493	Pakenham	CFA Running Track - John Street
152939	Pakenham	Deep Creek Public Toilets
131169	Pakenham	Lakeside Dragon Park Exeloo
173679	Pakenham	Rotary Park Exeloo
63406	Pakenham	Toomuc Rec Res Toilet Block
24540	Pakenham	Services Central External Toilet
499	Pakenham Upper	RJ Chambers Res - Bourkes Creek Road
24560	Tynong	Railway Ave

5.5 Summary Condition Rating Data

Summary -Cardinia Shire Council Public Toilets												
Table 1					Table 2	Table 3	Table 4	Table 5				
	Council Wards	Total SQM	Average Condition Rating 1 to 5 of all assessed elements.	Number of Public Toilet in Ward.	Year 1	Year 2 & 3	Year 2 & 3					
					Number of PT's with a Condition Element Ratings of 4 & 5.	Number of PT's with Condition Element Ratings of 3.	Number of PT's with Condition Element Ratings of 1 to 2	Number of PT 2019-20 corrective Plumbing repairs.				
1	A	506	2.1	12	4	3	5	7				
2	B	112	2.1	3	0	3	0	1				
3	C	173	2.2	5	1	4	0	4				
4	D			0	0	0	0					
5	E	80	1.6	2	0	1	1					
6	F			0	0	0	0					
7	G	58	1.9	4	1	1	2	2				
8	H			0	0	0	0					
9	I	550	2.3	9	5	3	1	9				
Totals					9	1479	2.0	35	11	15	9	23
Notes :												
Condition rating -												
1 = Very good - As new condition												
2 = Good condition - Very minor visual or physical deterioration.												
3 = Fair or average condition for its age - Functional, requiring programmed refurbishment or maintenance over next 2 to 3 years.												
4 - Poor Condition - May not be fully functional, poor aesthetic appearance. May require part or full repair or refurbishment.												
5 = Very Poor Condition - Not performing function - Requires repair or replacement.												
Ref.												
1 https://www.vec.vic.gov.au/reviews/Cardiniarr.html												
2 https://www.localgovernment.vic.gov.au/our-programs/local-government-act-2020/electoral-structure-changes-for-2020												
3 https://www.localgovernment.vic.gov.au/_data/assets/pdf_file/0025/464128/Cardinia-Single-Councillor-Boundaries-A3-v2final.pdf												

5.6 Planning and Budgeting Data

Cardinia Public Toilet Sites					Maintenance Required [1 year]							Medium Priority Maintenance Required (2-3 year)		
ASSET ID	Location	Address	Average - 1 To 5 rating. (1 - good, 5 very poor)	Ward Location	Elements ratings 4 & 5	No. of Element requirements	Budget	Description of Element 4 & 5 requirements.	Elements ratings 3	No. of Element requirements	Budget	Floor SQM	Comment.	
000271	Cockatoo	McBride Street	2.4	A	4.0	1	\$1,000.00	Replace Guttering.	3.0	3	\$12,000.00	27	Treat Rust, Paint anti Graffiti, walls and floor, sink, cisterns.	
000283	Emerald	ELP located behind kiosk	1.8	A								48		
000325	Emerald	ELP east of Lake Nobelius	2.5	A					3.0	6	\$10,000.00	25	Paint internal - external walls, floor. Replace paper dispensers. Clean roof and rust proof - \$50 sqm in A-G	
000326	Emerald	ELP Toilets, Showers & Change Area west of cafe	2.2	A	4.0	1	\$3,000.00	Strip and re-paint floor	3.0	2	\$2,500.00	62	Minor repair gutter.	
000327	Emerald	ELP NW side of Lake Treganowan	2.2	A					3.0	2	\$6,000.00	90	Strip and re-paint floor. Minor repair gutter.	
000335	Emerald	ELP Public Toilets next to Lions Den shelter	2.4	A	4.0	1	\$5,000.00	Strip and re-paint floor	3.0	3	\$6,000.00	106	Minor repair gutter. Clean roof. exclude full floor in rating 4 @300sqm.	
000375	Emerald	Belgrave -Gembrook Road (Near Library)	3.1	A	4.0	1	\$1,100.00	Repaint floor @25 sqm	3.0	5	\$11,000.00	25	Structural report on wall cracks and movement. Paint walls clean roof	
000376	Emerald	Ferris Road	2.0	A								17		
000393	Gembrook	Cnr Beesak East and Gembrook Road	1.0	A								43		
023609	Emerald	Puffin Bill Place - Kilmington Drive	1.4	A								38		
066097	Gembrook	Redwood Road	2.1	A					3.0	1	\$9,000.00	25	Full internal/external/floor paint recommended. @140sqm. Graffiti effected. (do now*)	
143877	Cockatoo	Exeloo	1.7	A										
000238	Beaconsfield Upper	Charing Cross Emerald Beaconsfield Rd	2.1	B					3.0	1	\$1,000.00	44	Paint posts and handrail	
000499	Pakenham Upper	RJ Chambers Res - Bourkes Creek Road	2.2	B					3.0	3	\$1,500.00	33	Re- Paint floor@30sqm, touch up paint walls and steel.	
024543	Beaconsfield	Exeloo - Beaconsfield Comfort Station Old Princes Hwy (cnr Woods St)	2.1	B					3.0	1	\$750.00	35	Clean roof/steel and rust proof. Touch up paint as required.	
000251	Bunyip	Main Street	2.1	C					3.0	1	\$6,500.00	25	Gutter , CG quotation (5474)	
000341	Garfield	Ritche Street	2.1	C					3.0	3	\$750.00	30	Minor touch up paint to walls and down pipe.	
000344	Garfield	Recreation Reserve Toilet Block	2.4	C	4.0	1	\$1,200.00	Replace down pipes	3.0	2	\$800.00	38	Toilet furniture (\$520). Minor fixes clean roof and gutters.	
000462	Garfield North	Mt Cannibal	2.0	C								33		

024560	Tynong	Railway Ave	2.2	C					3.0	4	\$5,800.00	47	Toilet furniture (\$4815) Detail clean and touch up paint.
063406	Pakenham	Toomuc Rec Res Toilet Block	2.0	E					3.0	1	\$750.00	80	Rust treat end touch up paint.
131169	Pakenham	Lakeside Dragon Park Exeloo	1.3	E									
000493	Pakenham	CFA Running Track - John Street	2.6	G	4.0	2	\$1,600.00	Replace guttering, down pipes and re paint floor @25sqm.	3.0	3	\$1,000.00	23	Minor touch-up paint and roof maint.
024540	Pakenham	Services Central External Toilet	1.8	G								35	
109089	Pakenham	Bourke Park	2.3	G					3.0	2	\$1,000.00		Touch up paint to ceiling, deep clean floor Graffiti affected.
152939	Pakenham	Creek Eco CREEK ECO CENTRE	1.1	G									Part of bigger building (new.)
000216	Bayles	664 Koo Wee Rup Road	1.9	I	4.0	1	\$5,000.00	Toilet Furniture(\$4814). Fittings not securely fixed to wall.				31	
000359	Koo Wee Rup	External Pool Toilets - Rossiter Road	2.5	I	4.0 8.5.0 & 3.0	3	\$8,500.00	Down pipe. Floor vinyl 50sqm (Asbestos?) Hot water service				223	Vinyl floor - part-of only
000368	Lang Lang	Jetty Lane and Foreshore Rd	2.3	I					3.0	4	\$4,000.00	41	Structural report on wall cracks and movement. Minor repairs
000407	Koo Wee Rup	310 Rossiter Road	2.2	I					3.0	4	\$3,000.00	47	Toilet furniture(\$690). Detailed clean and touch up paint.
000421	Lang Lang	Kester Kitchin Park	2.5	I	4.0	1	\$1,200.00	Replace broken tiles and deep clean floor	3.0	4	\$1,300.00	48	Deep clean and touch up paint.
000431	Nar Nar Goon	Rec Reserve Toilets - Spencer Street	2.7	I	4.0	1	\$2,500.00	Cracks structural report.	3.0	4	\$6,500.00	22	Toilet furniture(\$5311). Detailed clean and touch up paint. Pressure clean exterior walls. (May take off paint.)
000455	Lang Lang	Tennis Club, 3 Roseberry Street	2.4	I	4.0	1	\$1,100.00	Replace roof support poles	3.0	6	\$2,500.00	66	Steam clean carpets, replace vinyl floor. Deep clean toilet floors, clean roof.
000469	Nar Nar Goon	Main Street	2.4	I	4.0	1	\$2,150.00	Paint Floor @50sqm	3.0	3	\$6,500.00	44	Toilet furniture (\$4600). Detailed clean and touch up paint walls and support poles. Rust treat.
077662	Koo Wee Rup	Bus Terminal Public Toilets, 345 Rossiter Rd	2.1	I					3.0	1	\$750.00	28	Rut prof and touch-up paint.
Average over all.			2.1				\$33,350.00				\$101,100.00		

Cost Assumptions.		
Paint - floor	acid etch, 2 coats, non skid	\$43/sqm
Paint - walls	2 coats water based Anti-Graffiti	\$30/sqm
Gutters	Colour Bond	\$45/m
Down pipes	Colour bond +2 fittings	\$30/m +\$100
Vinyl	Anti-slip	\$80/sqm

Calculation template		\$5
Length	5	
Gutters	\$45.00	\$325.00
Down Pipes +\$100	\$50.00	250.0
Floor SQM	50	
Paint floor	\$43.00	\$2,150.00
Wall SQM	200	
Paint walls	\$50.00	\$10,000.00
Ceiling SQM	50	
Paint ceiling	\$50.00	\$2,500.00
		\$12,725.00

2.5
10
8 200

5.7 Community Consultation – What we have heard

5.7.1 Summary Notes

A survey of our community has recently been undertaken by Council between 22 June 2020 and 17 July 2020 to help inform the new Public Toilet Strategy.

The raw data captured 149 participants responding to various questions on public toilets including: (i) are public toilets perceived to be secure and safe to use, including if they are well-lit at night if still open? (ii) are opening and closing times and days appropriate for required needs? (iii) are public toilets in a reasonable condition for use? (iv) do public toilets have adequate facilities for people with a disability? (v) are public toilets in a reasonable clean state when in use? and (vi) are public toilets located in a position suitable for the community and public visitors?

The main key insights from initial review of the raw data of the people surveyed suggests the following:

- Emerald, Pakenham, Cockatoo, Gembrook, Garfield, Bunyip, are the most visited toilets with Beaconsfield, Nar Nar Goon, Beaconsfield Upper, Garfield North, Koo Wee Rup, Tynong, Bayles, Lang Lang and Pakenham Upper following thereafter.
- 29% use toilets at least weekly with 36% use toilets at least monthly.
- People are prepared to walk to the nearest public toilet less than 1km and around 5mins. There was a reasonable amount of variety in response to this question ranging from 200m to less than 1km. However, a number of people suggested that ‘having to walk 300 metres from a park to a public toilet with young kids is too far’.
- Around 88% stated that there are public places where public toilets facilities are needing to be provided.
- 48% indicated that public toilets are generally clean and well presented.
- 59% indicated that public toilets are in good condition and facilities provided work properly (e.g. toilets flush, taps turn on and off, hand basins drain, etc.)
- 64% indicated that they feel safe using public toilets.
- 68% indicated that there are insufficient suitable public toilets that allow them to be worried and concerned when needing to use toilets.
- 68% indicated that there are insufficient public toilets for them to be able to meet family or friends in public places.
- 49% indicated that there are a lack of suitable public toilet facilities that prevent them from being physically active as they would like to be.
- 63% indicated that there are sufficient wheelchair/mobility and scooter access in using toilets.
- 64% indicated that there are sufficient disability change facilities when using toilets.
- 68% indicated that there are sufficient unisex facilities when using toilets.
- 54% indicated that there are sufficient unisex facilities not to make it awkward when taking their child and using such facilities.
- 54% indicated that they are comfortable in using unisex toilet facilities.
- 61% indicated that there are insufficient baby change table facilities.
- 68% indicated that toilets are open when needed.
- 70% indicated that there is insufficient information about the location of public toilets and the facilities they offer.
- 79% indicated that public toilets need improvement.
- In order of preference features that are most important in public toilets are Fixtures to keep personal items off the floor, No touch fixtures and fittings, Open evenings and weekends, Hand-drying facilities, Natural light, Sanitary napkin disposal, Natural ventilation, Improved access for people with a disability, Baby change tables, Unisex toilets, Assistance rails, Sharps disposal, and Mirrors.

The above information has been utilised to inform on the Interim Action Plan as detailed in Table 1 on page 18 of the Strategy document.

5.7.2 Community Engagement Survey Raw Data

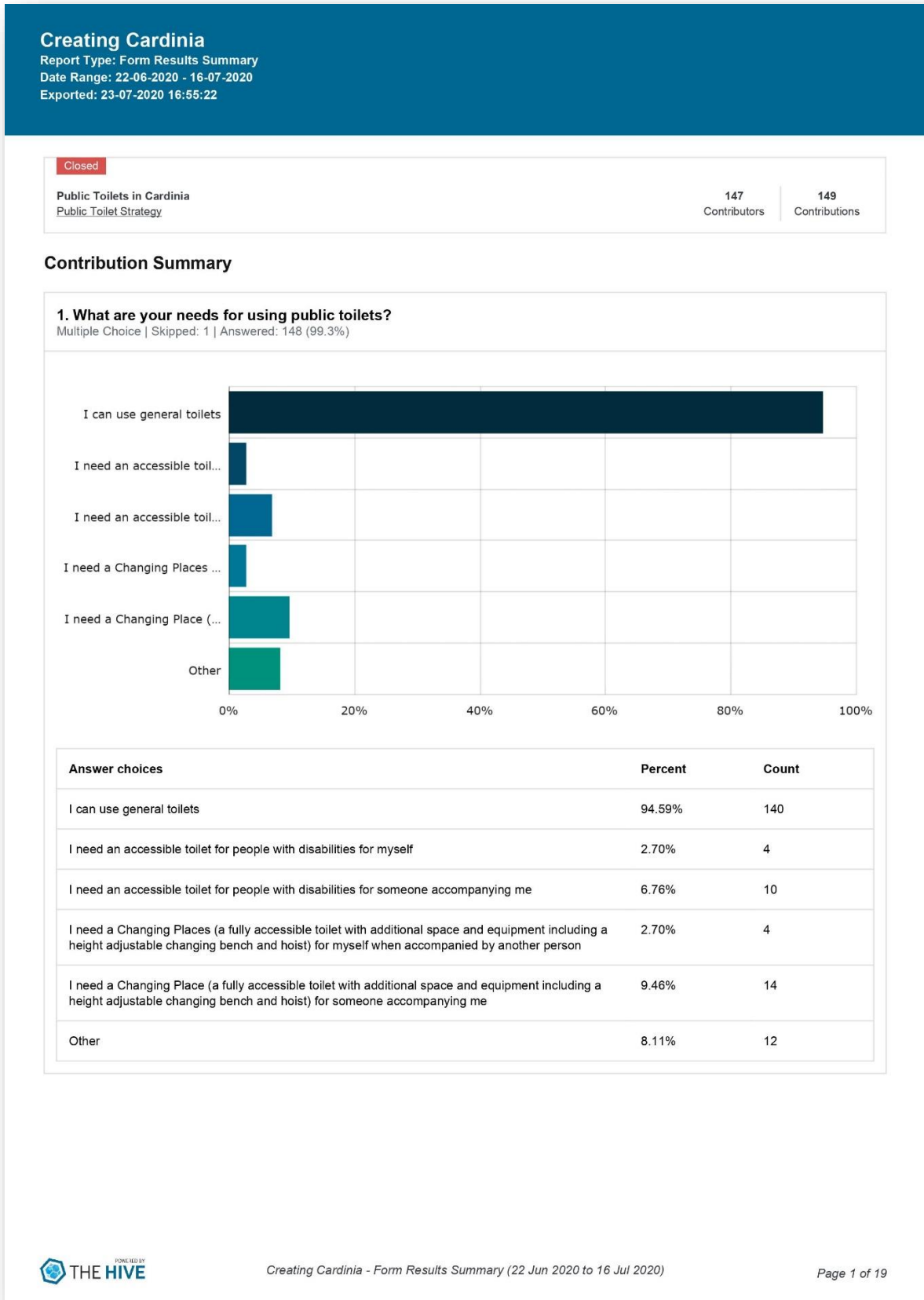

2. In the last 12 months, which of the following public toilets have you visited?

Multiple Choice | Skipped: 16 | Answered: 133 (89.3%)

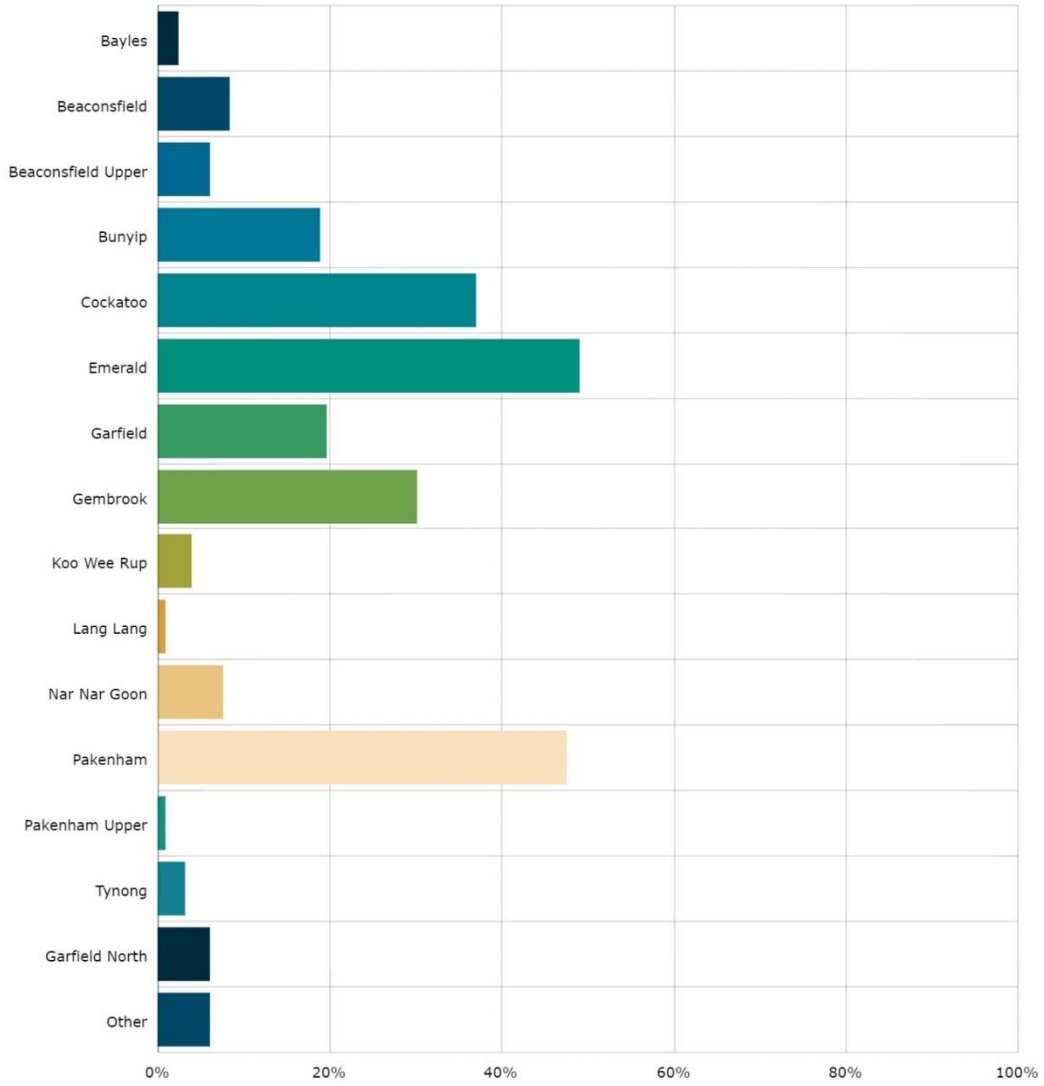

Answer choices	Percent	Count
Bayles	2.26%	3
Beaconsfield	8.27%	11
Beaconsfield Upper	6.02%	8

Bunyip	18.80%	25
Cockatoo	36.84%	49
Emerald	48.87%	65
Garfield	19.55%	26
Gembrook	30.08%	40
Koo Wee Rup	3.76%	5
Lang Lang	0.75%	1
Nar Nar Goon	7.52%	10
Pakenham	47.37%	63
Pakenham Upper	0.75%	1
Tynong	3.01%	4
Garfield North	6.02%	8
Other	6.02%	8

3. In the last 12 months, how often have you used public toilet facilities in Cardinia Shire?

Multiple Choice | Skipped: 3 | Answered: 146 (98%)

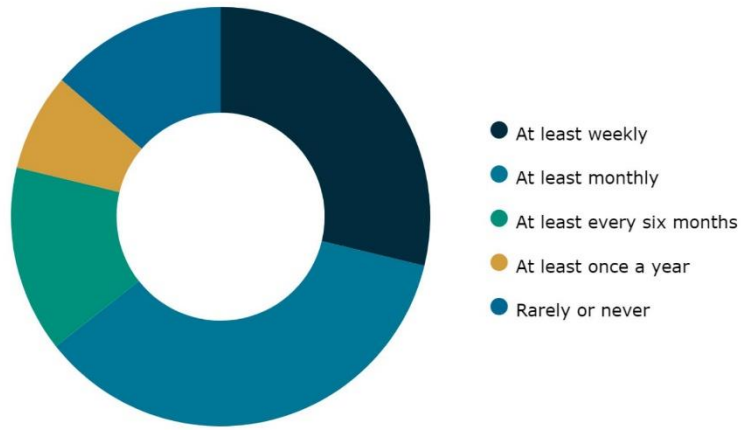

Answer choices	Percent	Count
At least weekly	28.77%	42
At least monthly	35.62%	52
At least every six months	14.38%	21
At least once a year	7.53%	11
Rarely or never	13.70%	20
Total	100.00%	146

4. How far are you prepared to walk/travel for a public toilet?

Long Text | Skipped: 17 | Answered: 132 (88.6%)

A reasonable walk

Contribution 132 of 132 | 16 July, 2020

Garfield needs a decent disability access toilet - not in the middle of the street where there is traffic. Can I suggest near the public BBQ area? there is much better parking there too and level ground

Contribution 131 of 132 | 16 July, 2020

It is good if they are close to Main Street.

Contribution 130 of 132 | 16 July, 2020

Depends on how desperate the toddler is! Ideally no more than a couple of hundred meters.

Contribution 129 of 132 | 16 July, 2020

Less than 1 km

Contribution 128 of 132 | 15 July, 2020

Not sure about this question, however, getting old unfortunately is equal to getting more frequent need to go to the toilet, I think I can exercise for an hour and a half than the needs to go to the toilet rises, not sure if that is what you are asking?

Contribution 127 of 132 | 11 July, 2020

200 metres

Contribution 126 of 132 | 10 July, 2020

Usually I use one while up the street shopping, or waiting for the bus.

Contribution 125 of 132 | 9 July, 2020

Depends on the area I am in and the circumstances. If parking is available and accessible path to the toilets

Contribution 124 of 132 | 6 July, 2020

Not far, 500 metres or so by foot

Contribution 123 of 132 | 6 July, 2020

needs to be close by

Contribution 122 of 132 | 6 July, 2020

When you need to access toilets you don't have time or possibly the health to walk the the 3/4 of a kilometre or so up into Bunyip or down to sports ground when at Koolongarra Park, especially with young children or older persons in tow. A public toilet ...

Contribution 121 of 132 | 5 July, 2020

<p>Considering I do a lot of walking in and around our reserves I would expect to see a toilet close by not have to travel home. An example would be the lake reserves in Cardinia Lakes. Contribution 120 of 132 3 July, 2020</p>
<p>5mins Contribution 119 of 132 3 July, 2020</p>
<p>They should be near areas that are populated, having to walk 300 metres from a park to a toilet with young kids is too far Contribution 118 of 132 3 July, 2020</p>
<p>Bunyip's park Needs a public toiletv Contribution 117 of 132 3 July, 2020</p>
<p>100mt Contribution 116 of 132 2 July, 2020</p>
<p>Up to 500m Contribution 115 of 132 2 July, 2020</p>
<p>I am one of the local kinder teachers and we like to frequently get out and about in the local community, however, if we do make a stop at the park children undoubtedly need the toilet within 5 minutes. Due to staff ratios and distance to a public toilet ... Contribution 114 of 132 2 July, 2020</p>
<p>However distance is necessary depending on the need Contribution 113 of 132 2 July, 2020</p>
<p>Showing 20 latest contributions only. Please see the data results for all contributions to this question.</p>

5. Please tell us if you agree or disagree with the following statements about public toilets in Cardinia Shire?

Matrix | Skipped: 1 | Answered: 148 (99.3%)

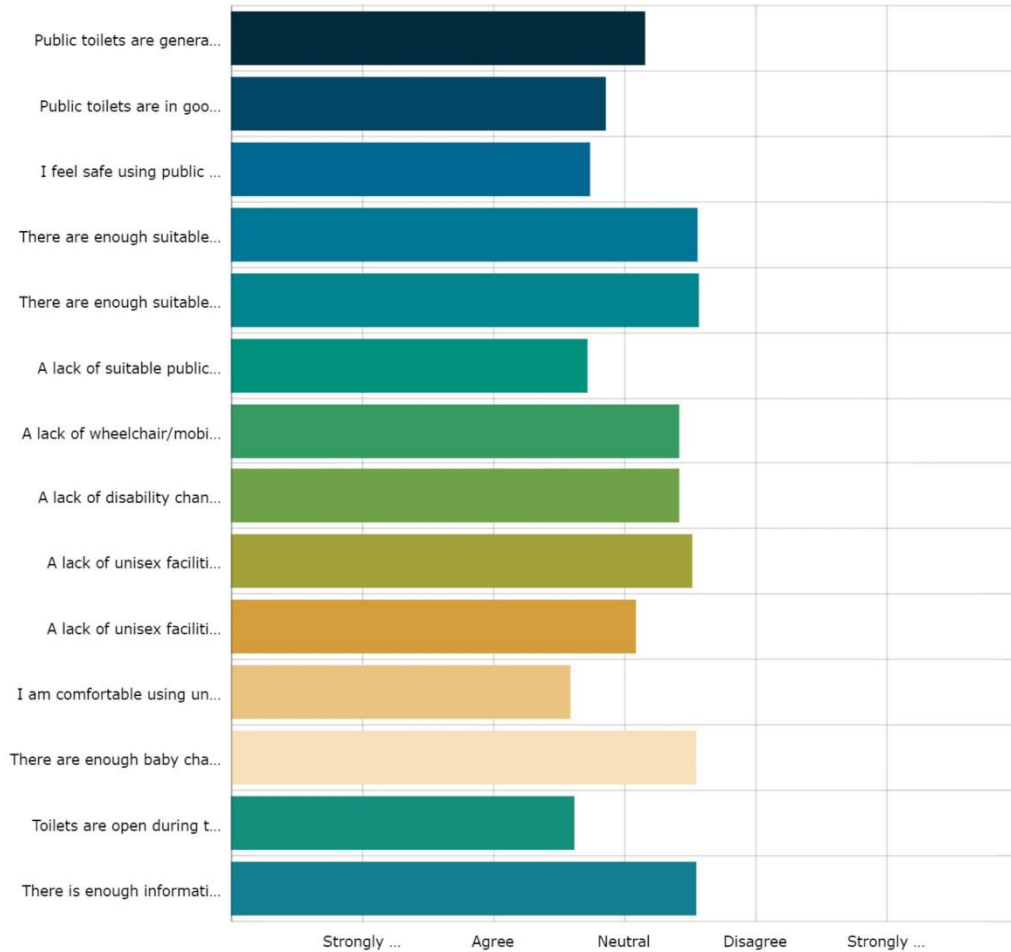

	Strongly agree	Agree	Neutral	Disagree	Strongly disagree	Count	Score
Public toilets are generally clean and well presented	2.72% 4	34.69% 51	20.41% 30	29.25% 43	12.93% 19	147	3.15
Public toilets are in good condition and facilities provided work	4.08% 6	44.22% 65	21.77% 32	22.45% 33	7.48% 11	147	2.85

properly (e.g. toilets flush, taps turn on and off, hand basins drain, etc.)							
I feel safe using public toilets in Cardinia Shire	4.79% 7	45.21% 66	28.08% 41	16.44% 24	5.48% 8	146	2.73
There are enough suitable public toilets to allow me to leave home without significant worry or concern about needing to use the toilet	2.72% 4	17.69% 26	21.77% 32	37.41% 55	20.41% 30	147	3.55
There are enough suitable toilet facilities for me to be able to meet family or friends in public places	1.36% 2	22.45% 33	16.33% 24	38.10% 56	21.77% 32	147	3.56
A lack of suitable public toilet facilities prevents me from being as physically active as I would like to be	17.01% 25	29.25% 43	25.17% 37	22.45% 33	6.12% 9	147	2.71
A lack of wheelchair/mobility scooter access prevents me from using public toilets	3.45% 5	5.52% 8	54.48% 79	20.00% 29	16.55% 24	145	3.41
A lack of disability change facilities prevents me from using public toilets	2.80% 4	6.29% 9	53.85% 77	20.98% 30	16.08% 23	143	3.41
A lack of unisex facilities prevents me	1.37% 2	9.59% 14	41.78% 61	30.82% 45	16.44% 24	146	3.51

from using public toilets							
A lack of unisex facilities makes it awkward for me to take my child into public toilets	8.97% 13	17.24% 25	40.69% 59	23.45% 34	9.66% 14	145	3.08
I am comfortable using unisex toilets	22.07% 32	32.41% 47	20.00% 29	16.55% 24	8.97% 13	145	2.58
There are enough baby change facilities in public toilets	2.78% 4	5.56% 8	43.06% 62	31.94% 46	16.67% 24	144	3.54
Toilets are open during the hours I need them	5.48% 8	49.32% 72	27.40% 40	14.38% 21	3.42% 5	146	2.61
There is enough information about the location of public toilets and the facilities they offer in Cardinia Shire	0.69% 1	14.48% 21	29.66% 43	40.69% 59	14.48% 21	145	3.54

6. Please tick the top 5 features that are most important to you in public toilets:

Multiple Choice | Skipped: 2 | Answered: 147 (98.7%)

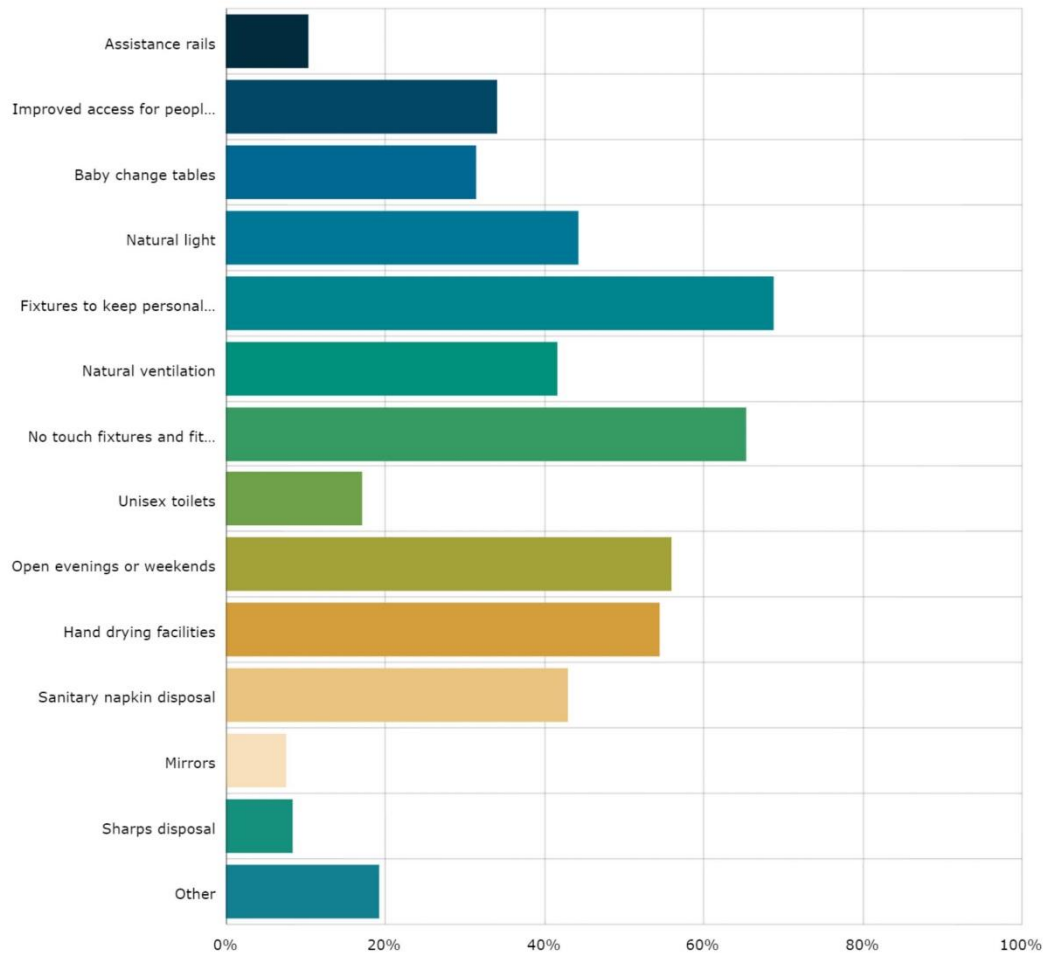

Answer choices	Percent	Count
Assistance rails	10.20%	15
Improved access for people with a disability	34.01%	50
Baby change tables	31.29%	46
Natural light	44.22%	65
Fixtures to keep personal items off the floor (e.g. door hooks, shelves)	68.71%	101

Natural ventilation	41.50%	61
No touch fixtures and fittings	65.31%	96
Unisex toilets	17.01%	25
Open evenings or weekends	55.78%	82
Hand drying facilities	54.42%	80
Sanitary napkin disposal	42.86%	63
Mirrors	7.48%	11
Sharps disposal	8.16%	12
Other	19.05%	28

7. Are there any public toilets in Cardinia Shire that need improvements?

Dropdown | Skipped: 22 | Answered: 127 (85.2%)

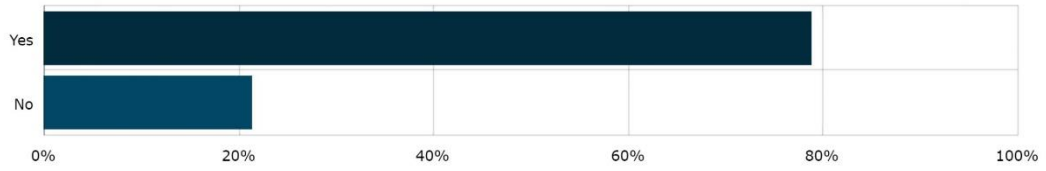

Answer choices	Percent	Count
Yes	78.74%	100
No	21.26%	27
Total	100.00%	127

8. Please tell us where

Long Text | Skipped: 46 | Answered: 103 (69.1%)

Bunyip definately need improved layout upgrade facilities Would be better to have a public toilet in the park on the corbner of Hope and Railway Ave.
Contribution 103 of 103 | 16 July, 2020

Garfield definately has no disabled access and is in middle of the street which is dangerous - better placed near public BBQ area up near the station
Contribution 102 of 103 | 16 July, 2020

Emerald next to mitre 10. Cockatoo at Alma reserve
Contribution 101 of 103 | 16 July, 2020

Emerald public toilets next to the new hub. I can't help but think if the zombie apocalypse was going to break out, it would be in those toilets. Great horror movie film location, terrible public toilets.
Contribution 100 of 103 | 15 July, 2020

N/A
Contribution 99 of 103 | 10 July, 2020

Cockatoo
Contribution 98 of 103 | 6 July, 2020

Gembrook: the new one is OK, the one near puffing billy station, can only access when puffing billy is open Toilets near reserve, over flowing water New Ex-a loo cockatoo, no shelter Cockatoo near playground need upgrading, and poor signage
Contribution 97 of 103 | 6 July, 2020

Bunyip sports ground they are not easily accessible
Contribution 96 of 103 | 5 July, 2020

Bunyip
Contribution 95 of 103 | 3 July, 2020

Emerald - Puffing Billy Park Emerald - Outside the Hills Hub Gembrook - New playspace Cockatoo - New pump track/playspace there are NO toilets.
Contribution 94 of 103 | 2 July, 2020

Bunyip at the park
Contribution 93 of 103 | 2 July, 2020

All large playgrounds need to have toilets
Contribution 92 of 103 | 2 July, 2020

<p>None that I am aware of. Contribution 91 of 103 2 July, 2020</p>
<p>Emerald , all toilets Outside the Hub in Emerald , disgusting ! Outside Mitre Ten Puffing Billy park Contribution 90 of 103 1 July, 2020</p>
<p>Emerald Lake Contribution 89 of 103 1 July, 2020</p>
<p>Emerald Lake Park Gembrook Park Upper Beaconsfield Alma Treloar in Cockatoo Contribution 88 of 103 1 July, 2020</p>
<p>Emerald!!! Both at the Puffing billy park and especially the ones near the new Hub Contribution 87 of 103 30 June, 2020</p>
<p>In front of the hills hub in emerald Contribution 86 of 103 30 June, 2020</p>
<p>Specifically public toilets in sports reserves, some examples Gembrook, officer, upper beaconsfield.....most in sports reserves are ignored by council Contribution 85 of 103 30 June, 2020</p>
<p>Gembrook playground Contribution 84 of 103 30 June, 2020</p>
<p>Showing 20 latest contributions only. Please see the data results for all contributions to this question.</p>

9. Are there any public spaces in Cardinia Shire where you would like to see toilet facilities provided?

Dropdown | Skipped: 21 | Answered: 128 (85.9%)

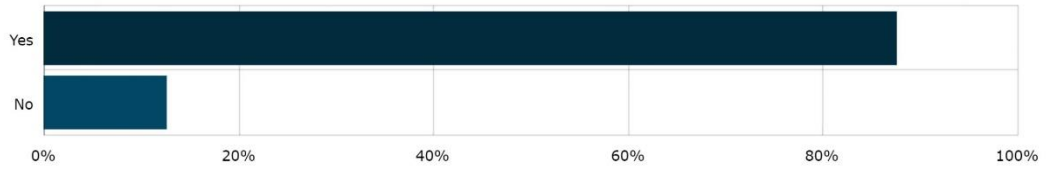

Answer choices	Percent	Count
Yes	87.50%	112
No	12.50%	16
Total	100.00%	128

10. If so, please tell us where

Long Text | Skipped: 38 | Answered: 111 (74.5%)

Would be better to have a public toilet in the park on the corner of Hope and Railway Ave.
Contribution 111 of 111 | 16 July, 2020

Garfield definatly has no disabled access and is in middle of the street which is dangerous - better placed near public BBQ area up near the station
Every public park where it would attract 200 - 300 visitors per week There is no proper public toilet at ...
Contribution 110 of 111 | 16 July, 2020

Cockatoo at the new playground Emerald at pepi's land
Contribution 109 of 111 | 16 July, 2020

Alma trealor reserve Cockatoo near the Allan Bailey hall. Unisex and suitable to accommodate parent and children.
Contribution 108 of 111 | 15 July, 2020

along toomuc creek,; BJ Wallis reserve
Contribution 107 of 111 | 11 July, 2020

Circuit Park (Waterford Rise Gardens, Lakeside). This park is used for a couple of large Lakeside events, up to 300 people, as well as many smaller local activities, parties etc.
Contribution 106 of 111 | 10 July, 2020

Bunyip - reserve near train crossing
Contribution 105 of 111 | 10 July, 2020

Koo wee rup viewing Tower on the South Gippsland Hwy and there is another rest stop further past Rossiter Road.
Contribution 104 of 111 | 6 July, 2020

Upper Beaconsfield, near shops
Contribution 103 of 111 | 6 July, 2020

Another one installed in Rotary Park southern end of park near Henry road. Also a toilet should be placed in the Cardinia Lakes estate around old quarry park.
Contribution 102 of 111 | 6 July, 2020

Koolongarra Park in Bunyip
Contribution 101 of 111 | 5 July, 2020

Cardinia Lakes
Contribution 100 of 111 | 3 July, 2020

<p>Jc russel park gembrook Contribution 99 of 111 3 July, 2020</p>
<p>Bunyip tractor Park. Its such a busy loved park but the nearest toilets are a few hundred metres away, not at all practical with young kids. The area is growing but nothing is evolving with it. Contribution 98 of 111 3 July, 2020</p>
<p>Bunyip Contribution 97 of 111 3 July, 2020</p>
<p>Bunyip Park on corner of Main & Hope street bunyip Contribution 96 of 111 2 July, 2020</p>
<p>At all playspaces for families with children especially when toilet training. We are a community with lots of young families and nearly no facilities. Contribution 95 of 111 2 July, 2020</p>
<p>Bunyip at the park Contribution 94 of 111 2 July, 2020</p>
<p>Playgrounds Contribution 93 of 111 2 July, 2020</p>
<p>Pepis land Contribution 92 of 111 1 July, 2020</p>
<p>Showing 20 latest contributions only. Please see the data results for all contributions to this question.</p>

11. Do you have any other comments about public toilet facilities in Cardinia Shire?

Long Text | Skipped: 69 | Answered: 80 (53.7%)

Add a public toilet in the BMX track in Bunyip? Need to upgrade this local area
Contribution 80 of 80 | 16 July, 2020

More change table facilities - especially at playgrounds
Contribution 79 of 80 | 16 July, 2020

Emerald and cockatoo need the existing public toilets renovated, they are outdated, un safe and un hygienic. I would also like to see environmentally friendly features such as solar power and rain water catchment used.
Contribution 78 of 80 | 15 July, 2020

I live in Toomuc Ward and the only public toilet I am aware of is at the Lakeside, and this is making it hard for me to explore the whole areas especially along Toomuc creek.
Contribution 77 of 80 | 11 July, 2020

The one near the station often seems dirty. It probably gets just heaps of usage.
Contribution 76 of 80 | 9 July, 2020

I would like to see design consideration for people with Dementia
Contribution 75 of 80 | 6 July, 2020

Toilets along walking tracks would be helpful.
Contribution 74 of 80 | 6 July, 2020

No!
Contribution 73 of 80 | 6 July, 2020

We need desperately toilets in the park in Bunyip. It is a very well used and popular park for families and friends to meet and play
Contribution 72 of 80 | 5 July, 2020

Generally not enough
Contribution 71 of 80 | 3 July, 2020

No
Contribution 70 of 80 | 3 July, 2020

The toilets at the Bunyip Rec Reserve behind the football club rooms need updating
Contribution 69 of 80 | 2 July, 2020

The toilets out side of the Hills Hub are disgusting and all locals avoid them at all costs. I have lived in Emerald for 7 years and have never used them due to their state. Considering under normal circumstances we have such a high level of tourism our t...
 Contribution 68 of 80 | 2 July, 2020

I strongly believe that vegetation near public toilets needs to be cleared and the toilets should be as visible to the public as much as possible. An example are the toilets ear Gumbaya World. These look dindgy and unsafe . Anyone caught there by undesira...
 Contribution 67 of 80 | 2 July, 2020

Personally I do not use them because physically I can wait a longer time to go! However, I am aware that others, not so well as me, need all the facilities you mention.
 Contribution 66 of 80 | 2 July, 2020

Clean them!
 Contribution 65 of 80 | 1 July, 2020

It was good to see the excel loo in Beaconsfield near the War memorial renovated. It is useful for people on the south side of the highway.
 Contribution 64 of 80 | 1 July, 2020

they are generally outdated and need to be refreshed with unisex and all abilities access. The refurbishments taking place are very good.
 Contribution 63 of 80 | 1 July, 2020

You need a drink fountain too at Puffing billy park
 Contribution 62 of 80 | 30 June, 2020

Essential to upgrade the facilities in Emerald for safe and clean after hours access for all visitors
 Contribution 61 of 80 | 30 June, 2020

Showing 20 latest contributions only. Please see the data results for all contributions to this question.

5.8 Pictures and Line Diagrams of Existing Public Toilets

5.8.1 Bayles (Asset ID 216)

PHOTO 1



PHOTO 2



PHOTO 3



PHOTO 4



PHOTO 5



PHOTO 6



PHOTO 7



PHOTO 8



PHOTO 9



PHOTO 10



PHOTO 11



PHOTO 12



PHOTO 13



PHOTO 14



PHOTO 15

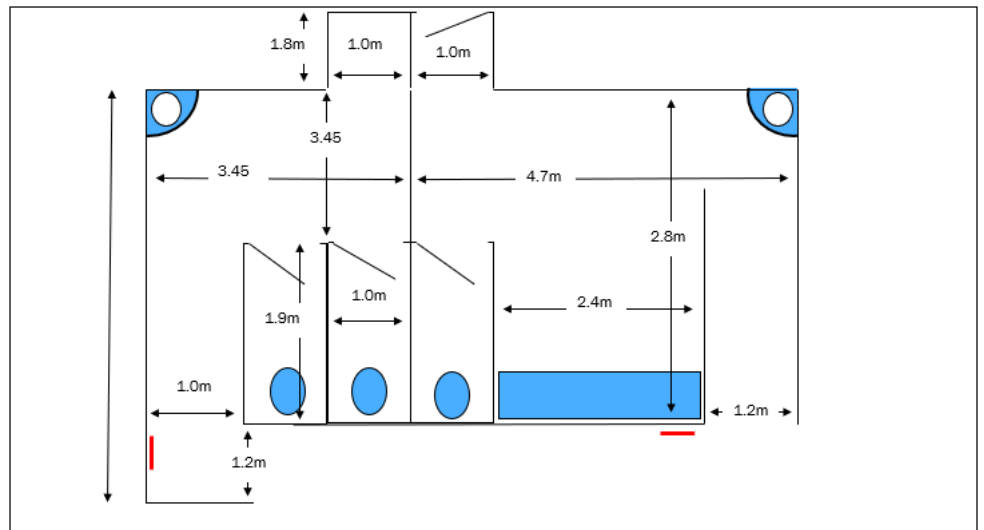

5.8.2 Beaconsfield Exeloo (Asset ID 24543)

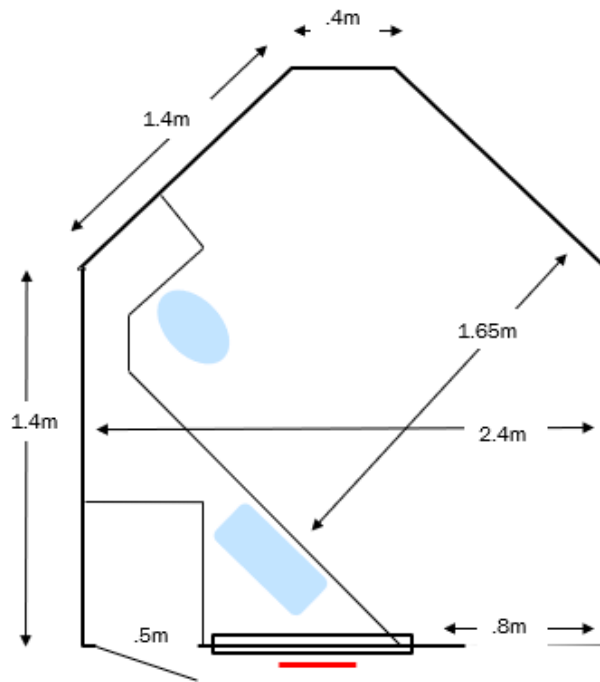

5.8.3 Beaconsfield Upper (Asset ID 238)

PHOTO 1



PHOTO 2



PHOTO 3



PHOTO 4



PHOTO 5



PHOTO 6



PHOTO 7



PHOTO 8



PHOTO 9



PHOTO 10



PHOTO 11



PHOTO 12



PHOTO 13



PHOTO 14



PHOTO 15



PHOTO 16



← 6.5MM →

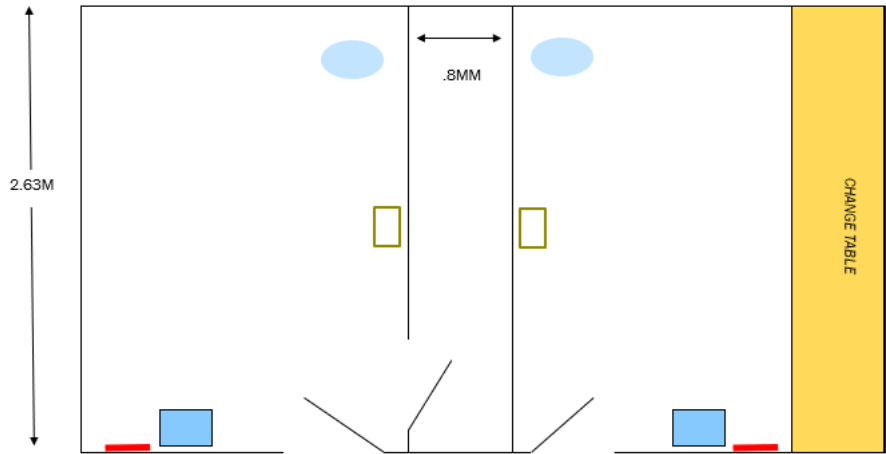

5.8.4 Bunyip (Asset ID 251)

PHOTO 1



PHOTO 2



PHOTO 3



PHOTO 4



PHOTO 5



PHOTO 6



PHOTO 7



PHOTO 8



PHOTO 9



PHOTO 10

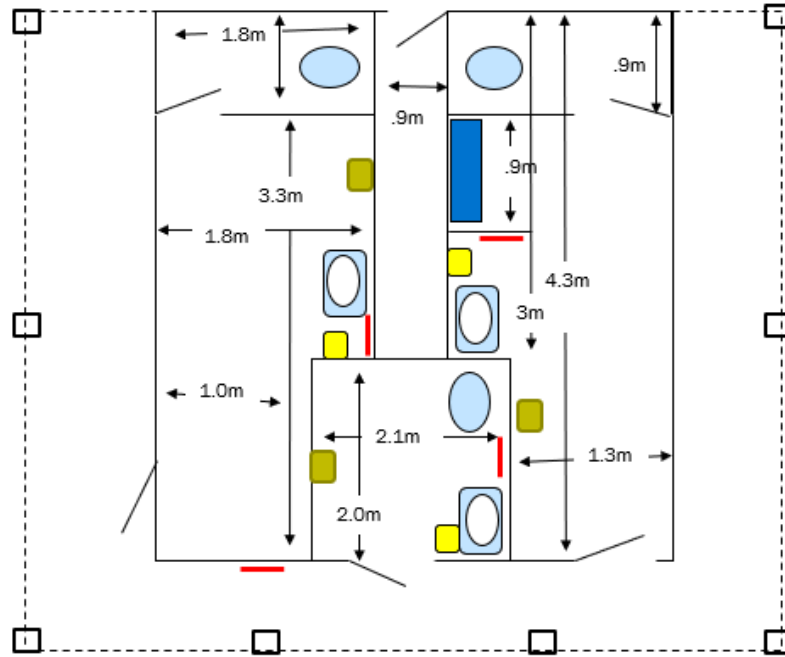

PHOTO 11



PHOTO 12





5.8.5 Cockatoo Exeloo (Asset ID 143877)



5.8.6 Cockatoo Alma Treloar (Asset ID 271)

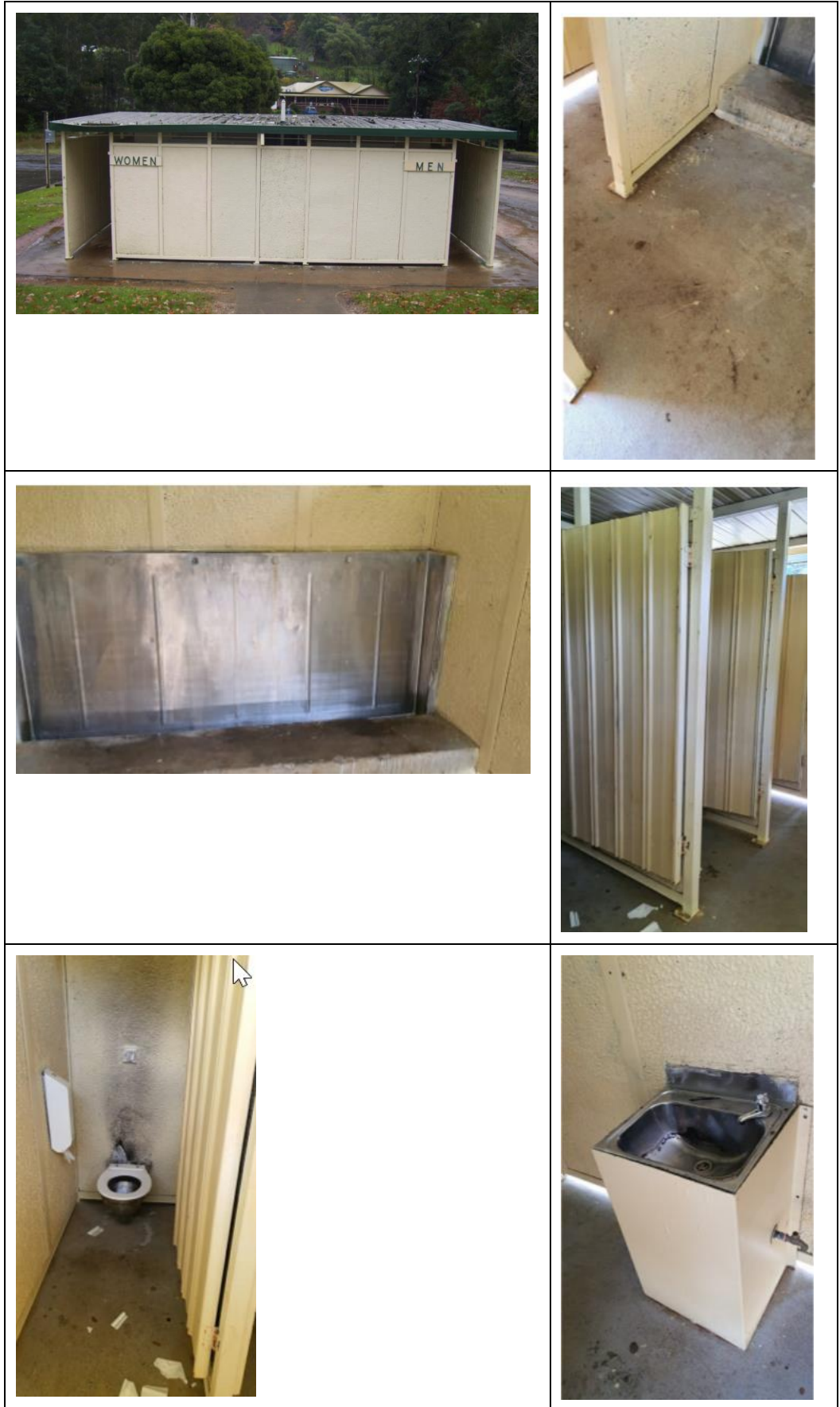

5.8.7 Emerald Puffing Billy (Asset ID 23609)

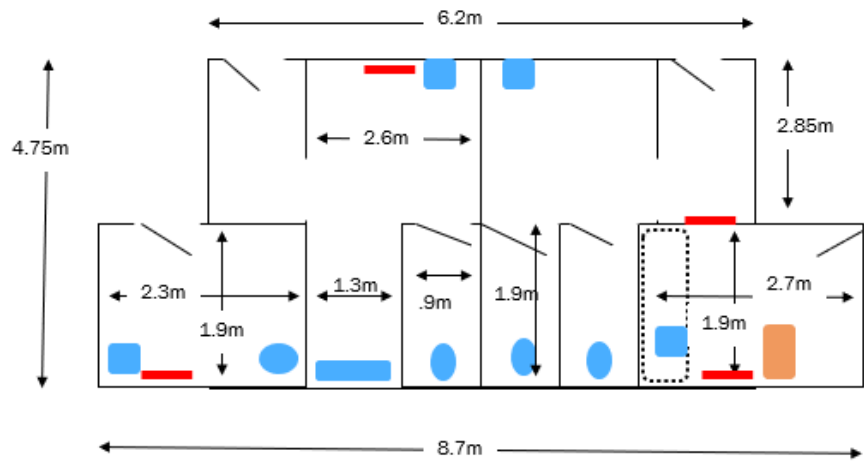
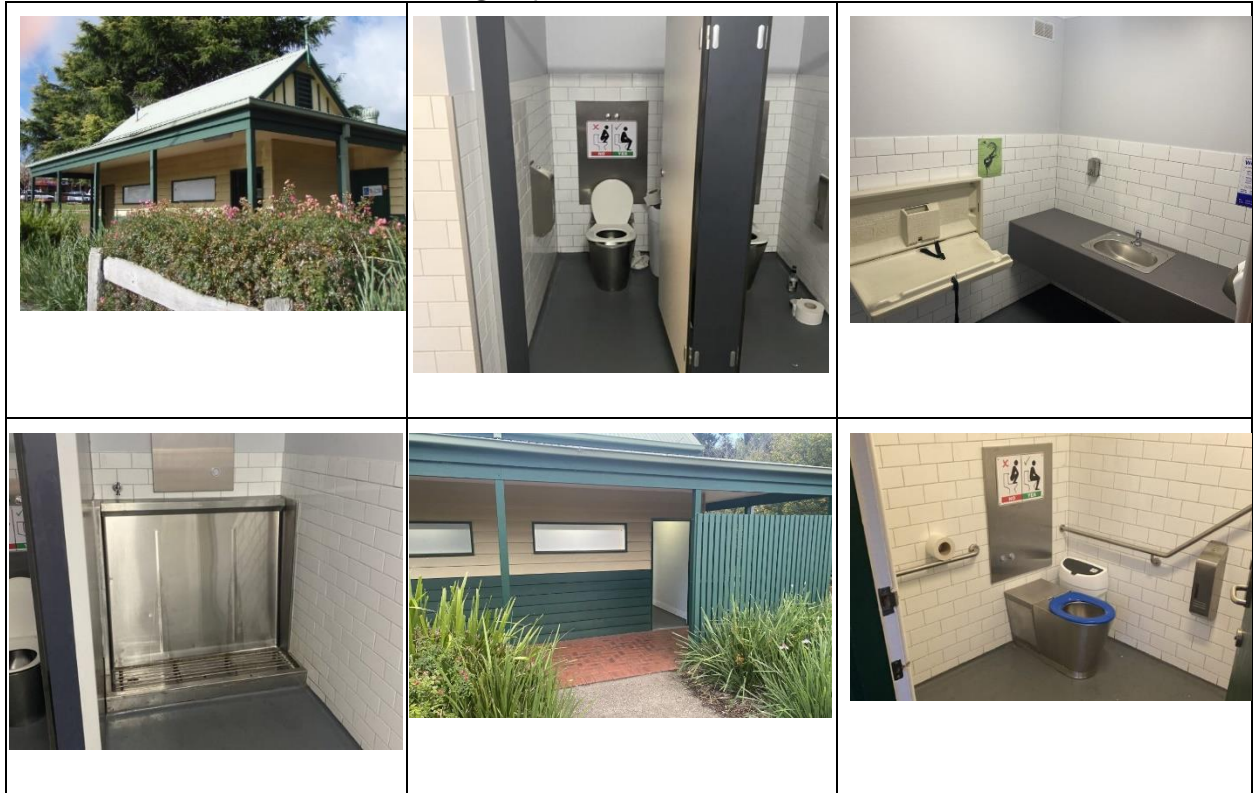

5.8.8 Emerald near library (Asset ID 375)

PHOTO 1



PHOTO 2



PHOTO 3



PHOTO 4



PHOTO 5



PHOTO 6



PHOTO 7



PHOTO 8

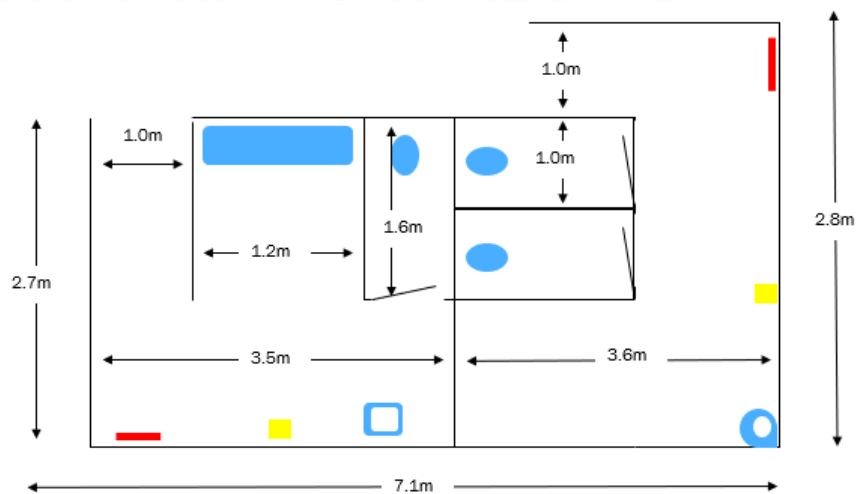

5.8.9 Emerald Ferris Road (Asset ID 376)

PHOTO 1



PHOTO 2



PHOTO 3



PHOTO 4



PHOTO 5



PHOTO 6



PHOTO 7



PHOTO 8



PHOTO 9



PHOTO 10

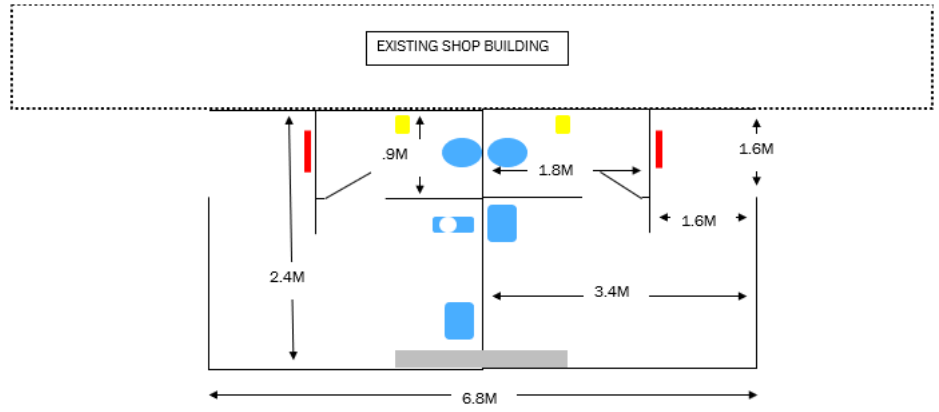

PHOTO 11

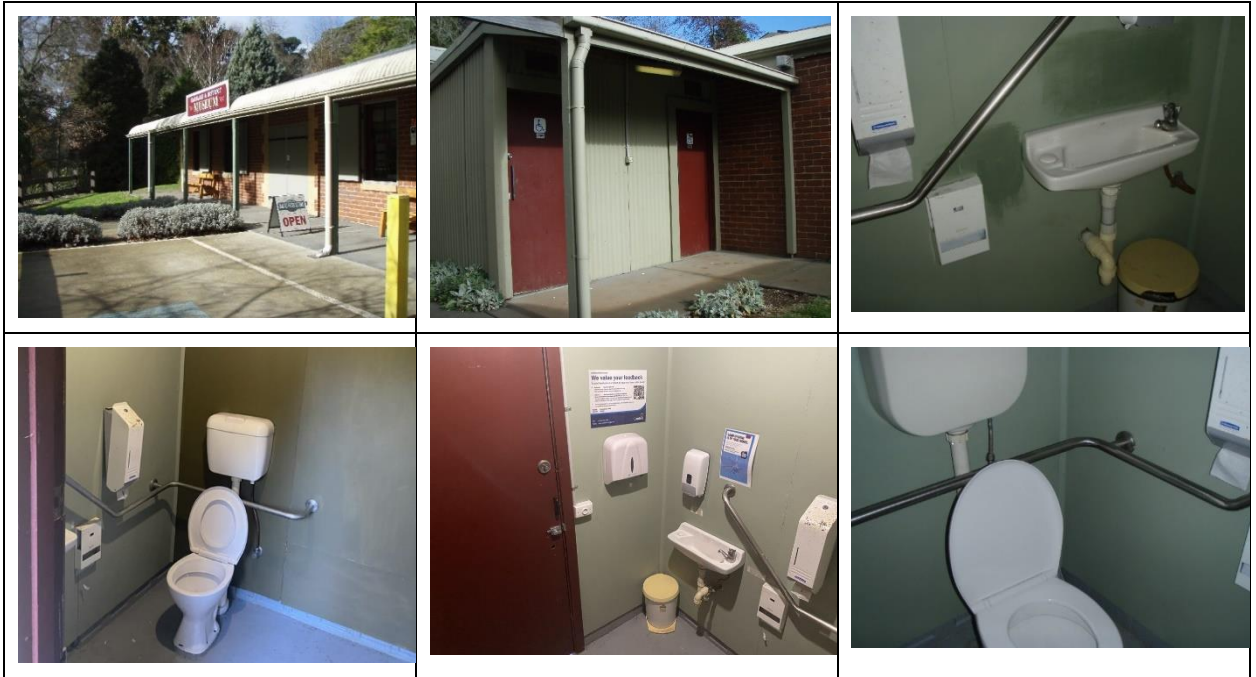
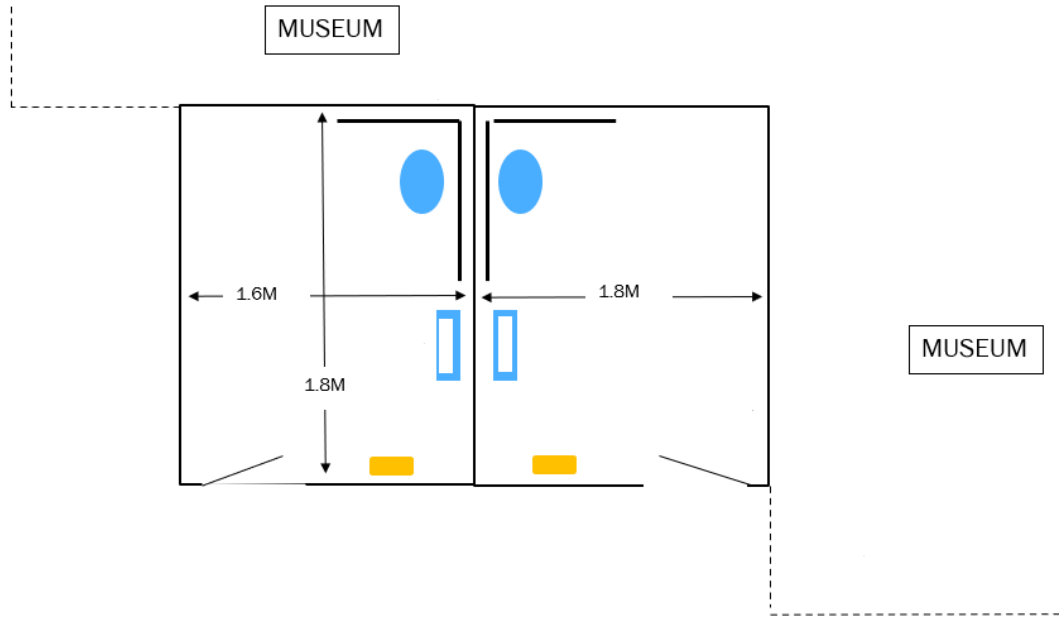

PHOTO 12





5.8.10 Emerald Museum



5.8.10 ELP Bandstand toilet block (Asset ID 326)

PHOTO 1



PHOTO 2



PHOTO 3



PHOTO 4



PHOTO 5

PHOTO 6

PHOTO 7



PHOTO 8

PHOTO 9



PHOTO 10

PHOTO 11



PHOTO 12

PHOTO 13



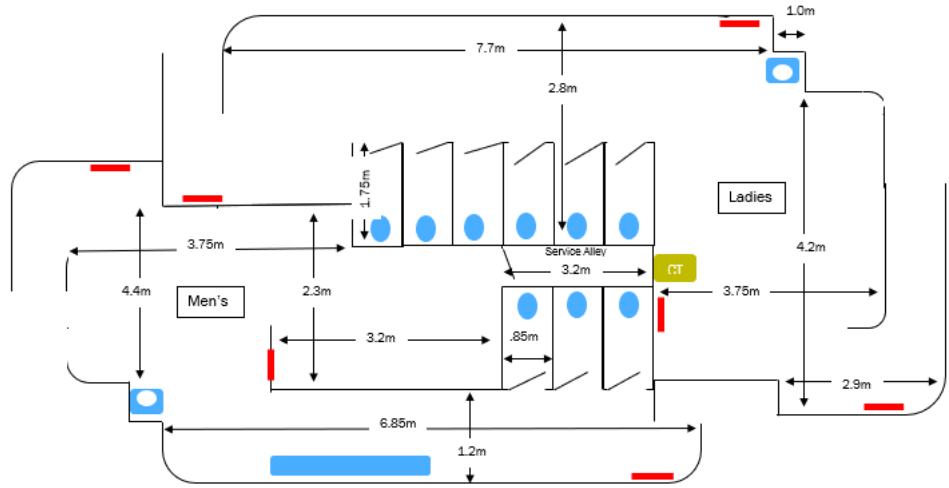

5.8.11 ELP Lake Park Lake Treganowan toilet block (Asset ID 327)

PHOTO 1



PHOTO 2



PHOTO 3



PHOTO 4



PHOTO 5



PHOTO 6



PHOTO 7



PHOTO 8



PHOTO 9



PHOTO 10



PHOTO 11



PHOTO 12



PHOTO 13



PHOTO 14



PHOTO 15



PHOTO 16



PHOTO 17



PHOTO 18



PHOTO 19



PHOTO 20



PHOTO 21

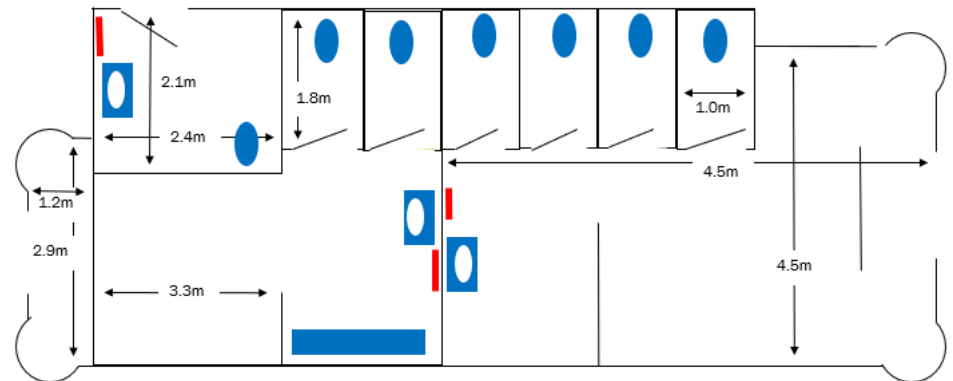

5.8.12 ELP east of Lake Nobelius (Asset ID 325)

PHOTO 1



PHOTO 2



PHOTO 3



PHOTO 4



PHOTO 5



PHOTO 6



PHOTO 7

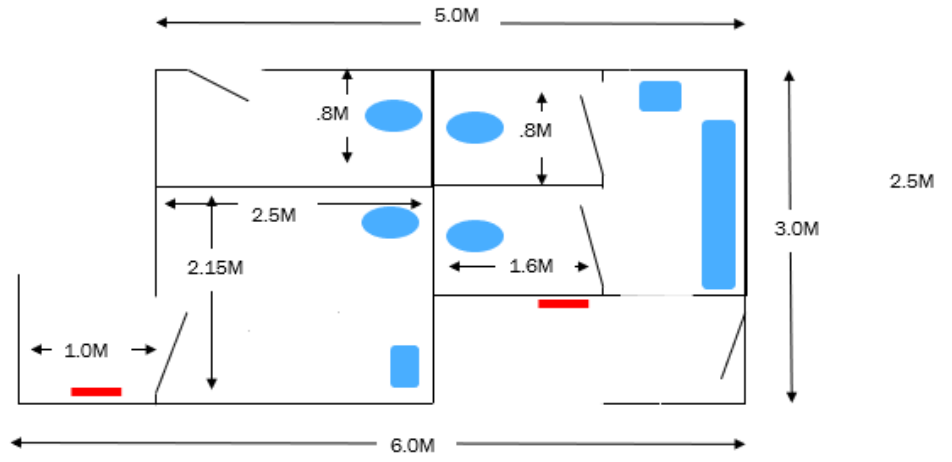

PHOTO 8



PHOTO 9





5.8.13 ELP located behind kiosk (Asset ID 283)

PHOTO 1



PHOTO 2



PHOTO 3



PHOTO 4



PHOTO 5



PHOTO 6



PHOTO 7



PHOTO 8



PHOTO 9



PHOTO 10



PHOTO 11



PHOTO 12



PHOTO 13



PHOTO 14



PHOTO 15



PHOTO 16

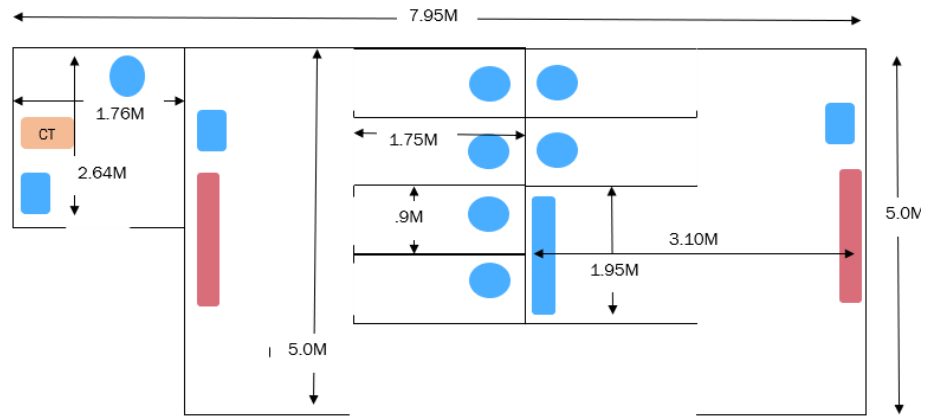

5.8.14 ELP Public Toilets next to Lions Den shelter (Asset ID 335)

PHOTO 1



PHOTO 2



PHOTO 3



PHOTO 4



PHOTO 5



PHOTO 6



PHOTO 7



PHOTO 8



PHOTO 9



PHOTO 10

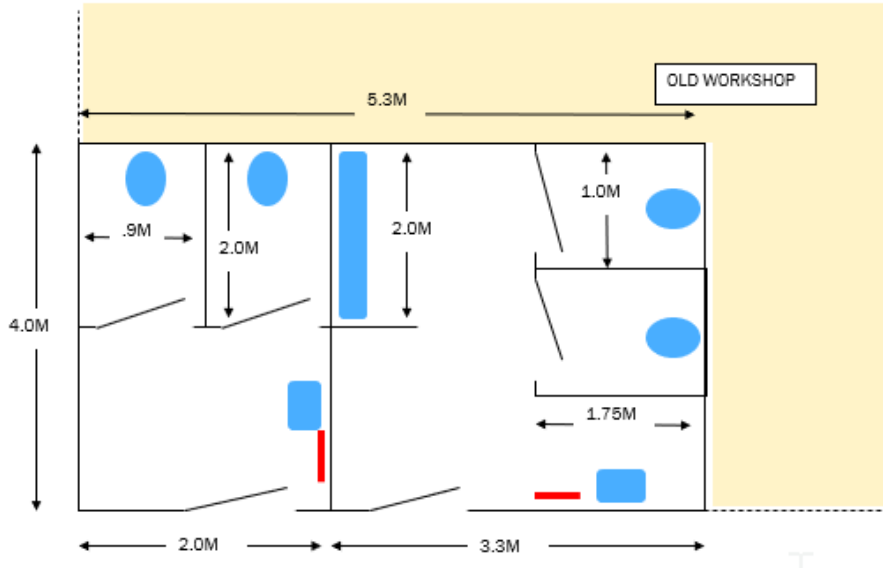

PHOTO 11



PHOTO 12





5.8.15 Garfield Ritchie Street (Asset ID 341)

PHOTO 1



PHOTO 2



PHOTO 3



PHOTO 4



PHOTO 5



PHOTO 6



PHOTO 7



photo 8



PHOTO 9



PHOTO 10



PHOTO 11

PHOTO 12



PHOTO 13

PHOTO 14



PHOTO 15

PHOTO 16



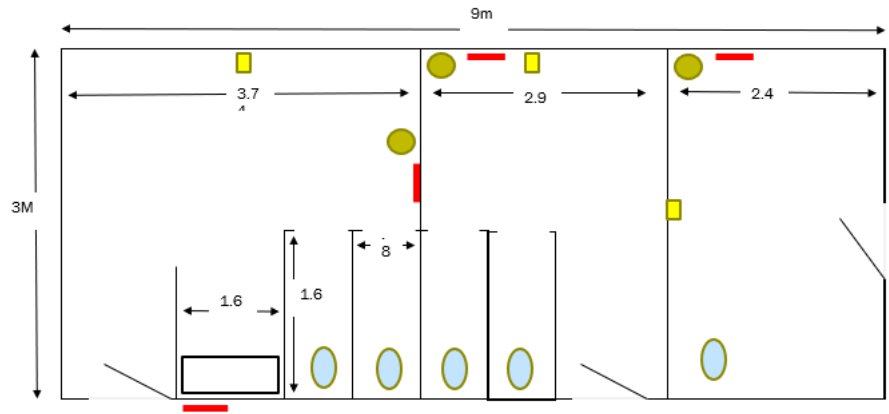

5.8.16 Garfield Recreation Reserve (Asset ID 344)

PHOTO 1



PHOTO 2



PHOTO 3



PHOTO 4



PHOTO 5



PHOTO 6



PHOTO 7



photo 8



PHOTO 9



PHOTO 10



PHOTO 11



PHOTO 12



PHOTO 13



PHOTO 14



PHOTO 15



PHOTO 16



PHOTO 17



PHOTO 18

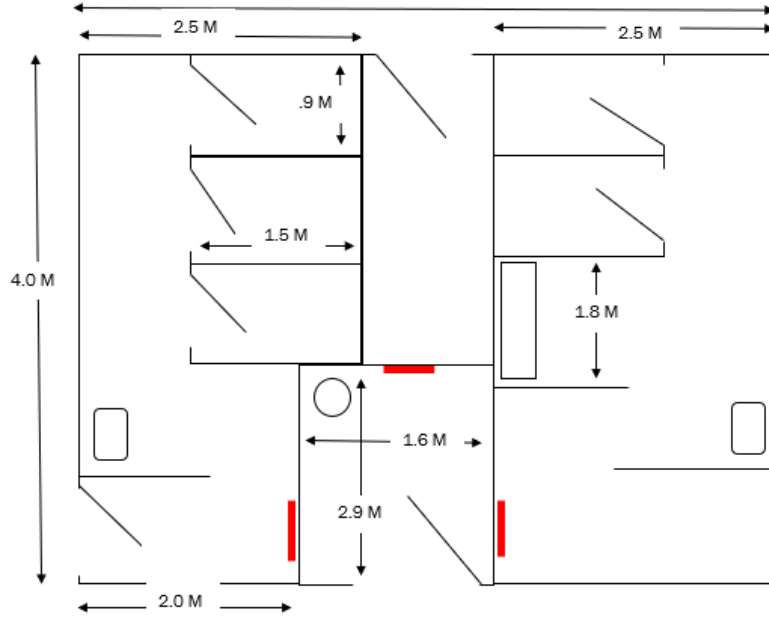

5.8.17 Garfield North Mt Cannibal (Asset ID 462)

PHOTO 1



PHOTO 2



PHOTO 3



PHOTO 4



PHOTO 5



PHOTO 6



PHOTO 7



photo 8



PHOTO 9



PHOTO 10



PHOTO 11



PHOTO 12



PHOTO 13



PHOTO 14



PHOTO 15



PHOTO 16



PHOTO 17



PHOTO 18

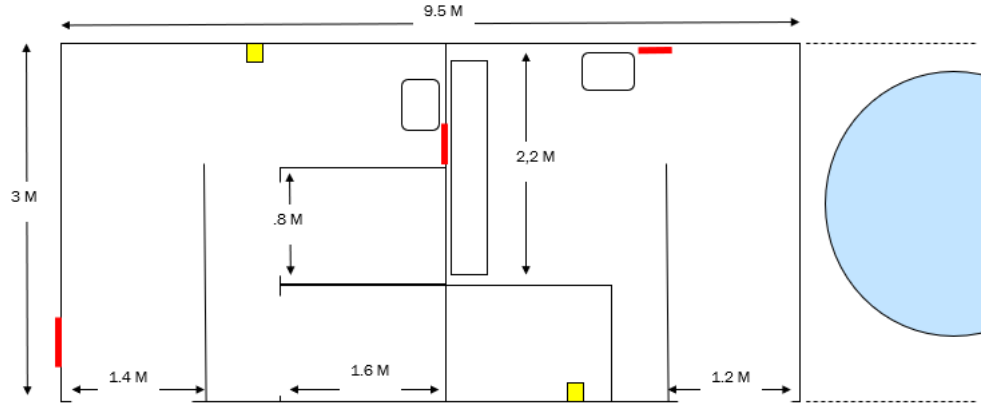

5.8.18 Gembrook Cnr Beemak East and Gembrook Road (Asset ID 393)

PHOTO 1



PHOTO 2



PHOTO 3



PHOTO 4



PHOTO 5



PHOTO 6



PHOTO 7



PHOTO 8



PHOTO 9



PHOTO 10



PHOTO 11



PHOTO 12



PHOTO 13



PHOTO 14



PHOTO 15



PHOTO 16



PHOTO 17



PHOTO 18



PHOTO 19



PHOTO 20



PHOTO 21



PHOTO 22



PHOTO 23



PHOTO 24



PHOTO 25



PHOTO 26



PHOTO 27



photo 28



PHOTO 29



PHOTO 30



PHOTO 31



PHOTO 32

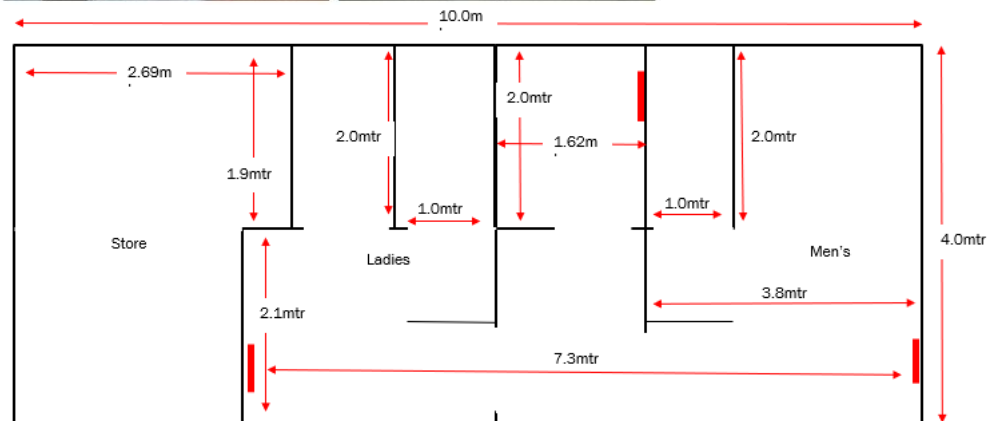

5.8.19 Gembrook Redwood Road (Asset ID 66097)

PHOTO 11



PHOTO 12



PHOTO 13



PHOTO 14



PHOTO 15



PHOTO 16



PHOTO 17



PHOTO 18



PHOTO 19



PHOTO 20



PHOTO 21



PHOTO 22



PHOTO 23



PHOTO 24



PHOTO 25



PHOTO 26



PHOTO 27



PHOTO 28



PHOTO 29



PHOTO 30



PHOTO 31

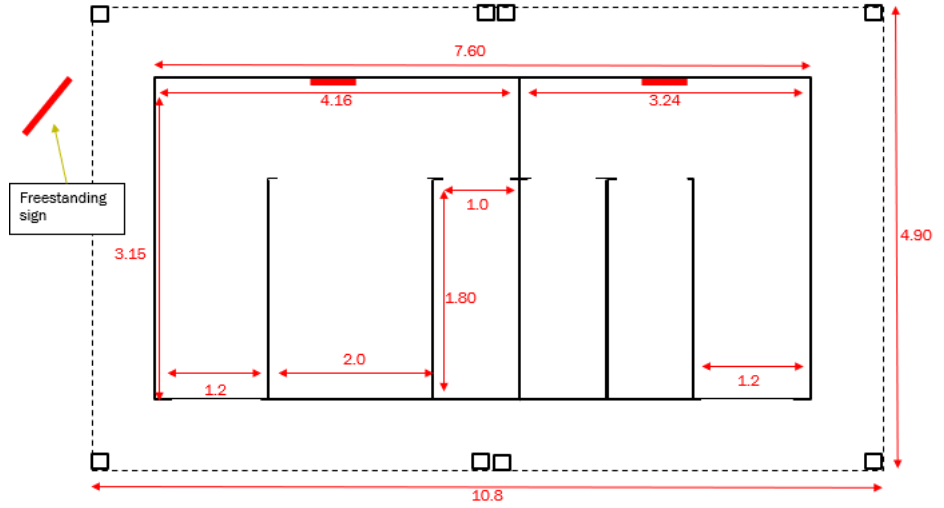

PHOTO 32



PHOTO 33





5.8.20 Koo Wee Rup Bus Terminal (Asset ID 77662)

PHOTO 1



PHOTO 2



PHOTO 3



PHOTO 4



PHOTO 5



PHOTO 6



PHOTO 7



PHOTO 8

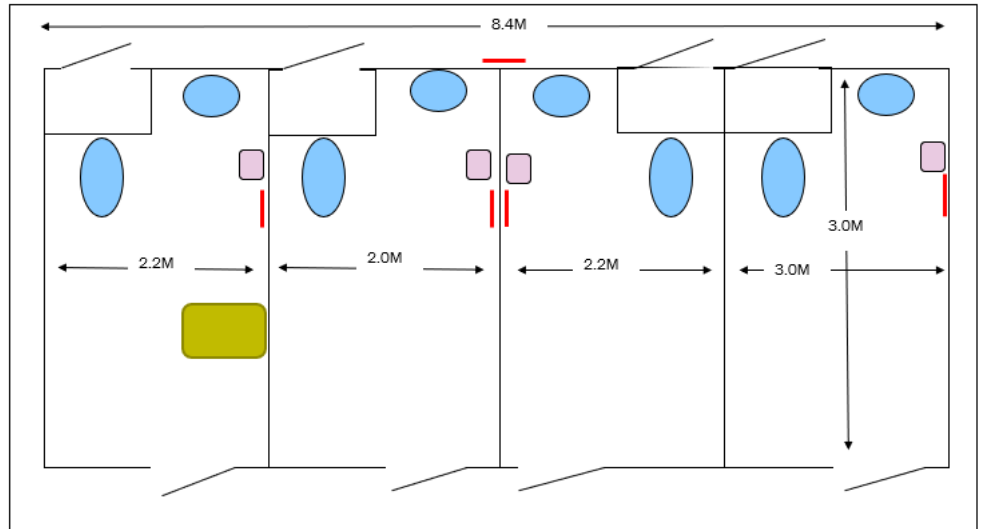

PHOTO 9



PHOTO 10





5.8.21 Koo Wee Rup 310 Rossiter Road (Asset ID 407)

PHOTO 1



PHOTO 2



PHOTO 3



PHOTO 4

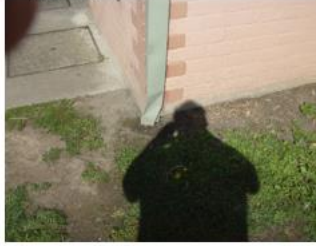

PHOTO 5



PHOTO 6



PHOTO 7



PHOTO 8



PHOTO 9



PHOTO 10



PHOTO 11



PHOTO 12



PHOTO 13



PHOTO 14



PHOTO 15



PHOTO 16



PHOTO 17



PHOTO 18



PHOTO 19



PHOTO 20



PHOTO 21



PHOTO 22



PHOTO 23



PHOTO 24



PHOTO 25



PHOTO 26



PHOTO 27



PHOTO 28



PHOTO 29



PHOTO 30



PHOTO 31



PHOTO 32

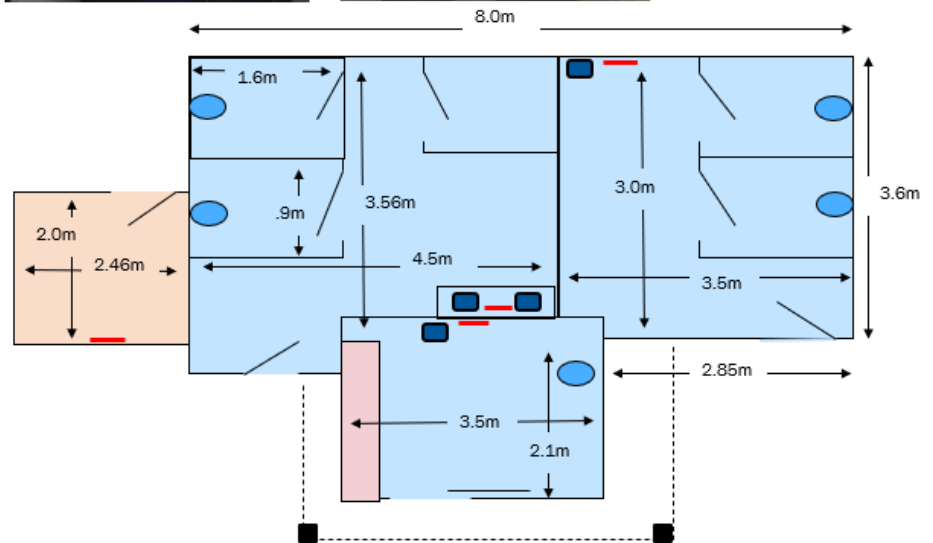

5.8.22 Koo Wee Rup External Pool Toilets (Asset ID 359)

PHOTO 1



PHOTO 2



PHOTO 3



PHOTO 4



PHOTO 5



PHOTO 6



3.0m

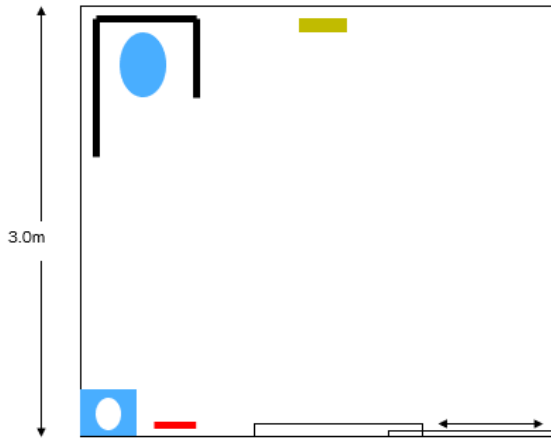

PHOTO 1



PHOTO 2



PHOTO 3



PHOTO 4



PHOTO 5



PHOTO 6



PHOTO 7



PHOTO 8



MALE TOILETS

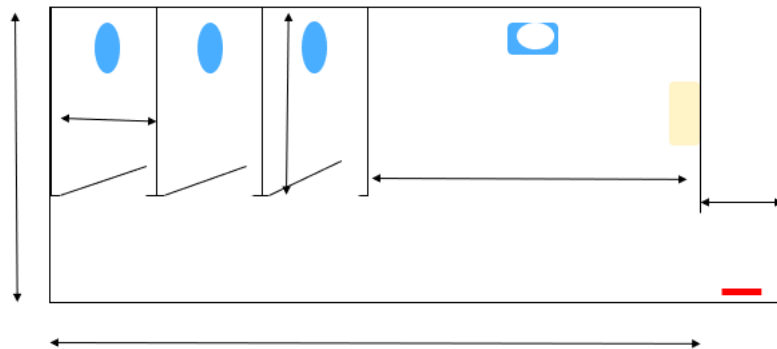
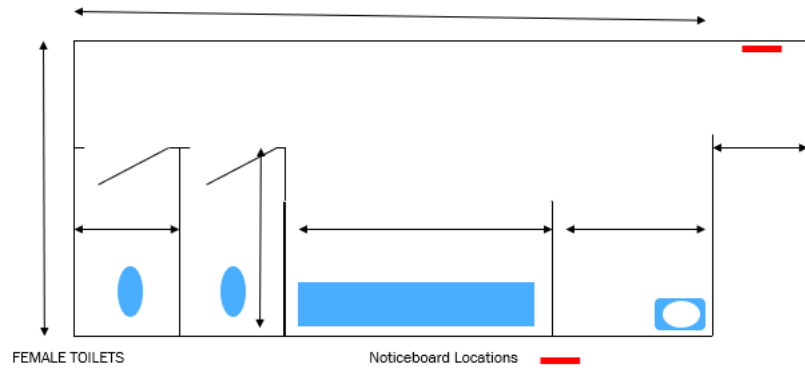

PHOTO 9



PHOTO 10



PHOTO 11



PHOTO 12



PHOTO 13



PHOTO 14



5.8.23 Lang Lang Kester Kitchin Park (Asset ID 421)

PHOTO 1



PHOTO 2



PHOTO 3



PHOTO 4



PHOTO 5



PHOTO 6



PHOTO 7



PHOTO 8



PHOTO 9



PHOTO 10



PHOTO 11



PHOTO 12



PHOTO 13



PHOTO 14



PHOTO 15

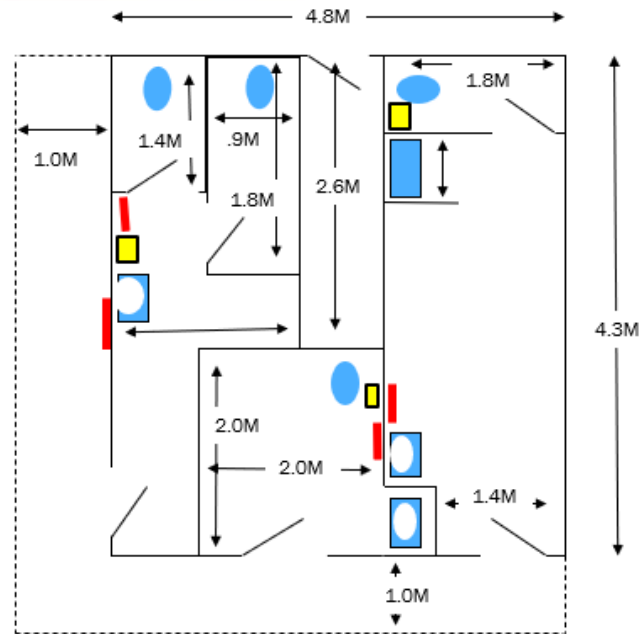

5.8.24 Lang Lang Jetty Lane and Foreshore Rd (Asset ID 368)

PHOTO 1



PHOTO 2



PHOTO 3



PHOTO 4



PHOTO 5



PHOTO 6



PHOTO 7



PHOTO 8



PHOTO 9



PHOTO 10



PHOTO 11



PHOTO 12



PHOTO 13



PHOTO 14



PHOTO 15



PHOTO 16

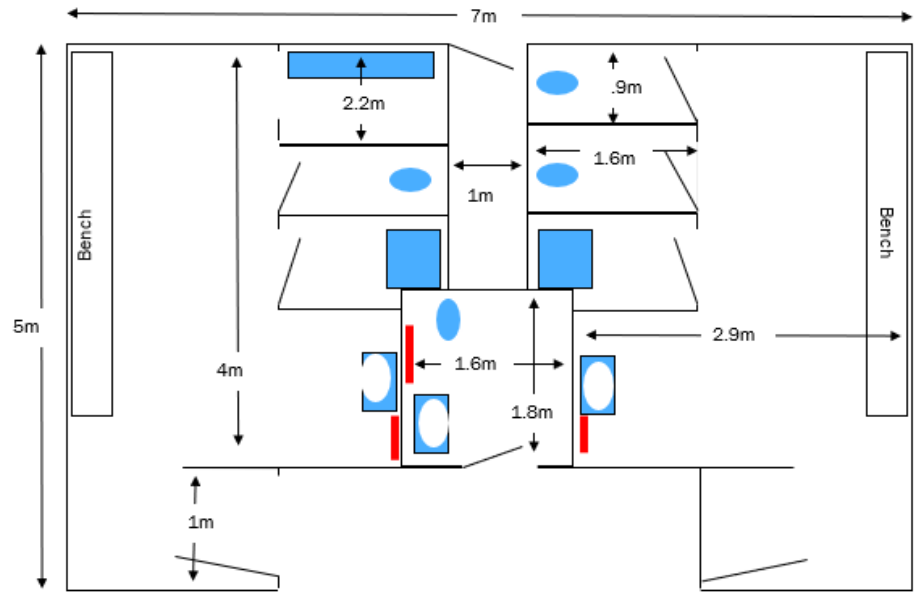

PHOTO 17



PHOTO 18





5.8.25 Lang Lang Tennis Club (Asset ID 455)

PHOTO 3



PHOTO 4



PHOTO 5



PHOTO 6



PHOTO 7

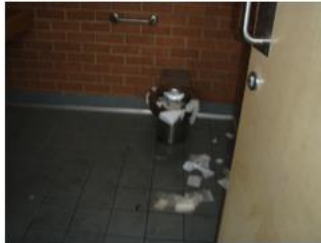

PHOTO 8



PHOTO 9



PHOTO 10



PHOTO 11



PHOTO 12

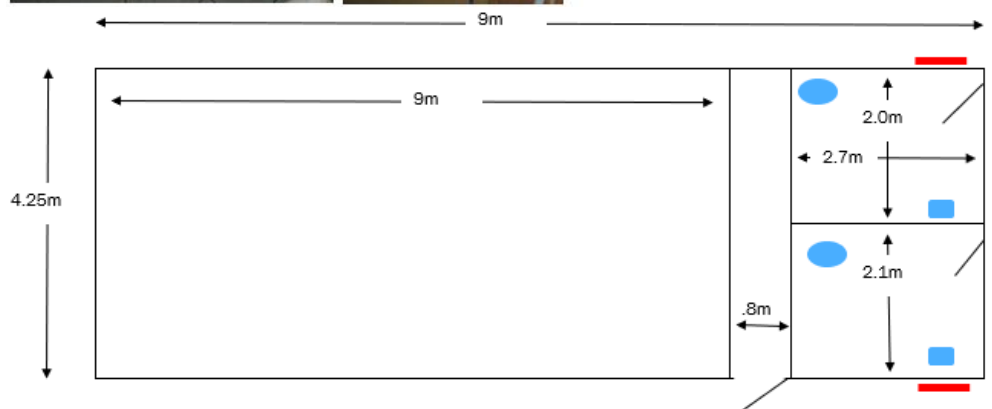

5.8.26 Nar Nar Goon Main Street (Asset ID 469)

PHOTO 1



PHOTO 2



PHOTO 3



PHOTO 4



PHOTO 5

PHOTO 6



PHOTO 7

PHOTO 8

PHOTO 9



PHOTO 10 PHOTO 11



PHOTO 12

PHOTO 13



PHOTO 14



PHOTO 15



PHOTO 16



PHOTO 17



9.2m

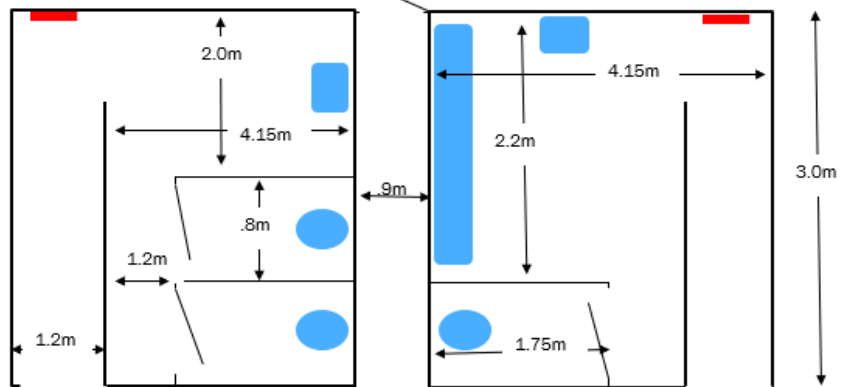

5.8.27 Nar Nar Goon Recreation Reserve (Asset ID 431)

PHOTO 1



PHOTO 2



PHOTO 3



PHOTO 4



PHOTO 5



PHOTO 6



PHOTO 7



PHOTO 8



PHOTO 9



PHOTO 10



PHOTO 11



PHOTO 12



PHOTO 13



PHOTO 14



PHOTO 15



PHOTO 16



PHOTO 17

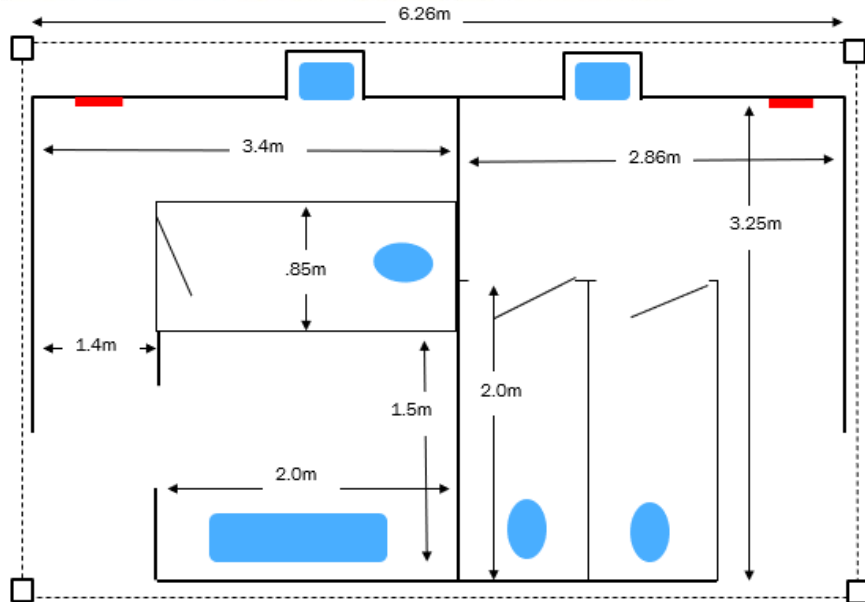

5.8.28 Pakenham Bourke Park Exeloo (Asset ID 109089)



5.8.29 Pakenham CFA Running Track (Asset ID 493)

PHOTO 1



PHOTO 2



PHOTO 3



PHOTO 4



PHOTO 5



PHOTO 6



PHOTO 7

PHOTO 8



PHOTO 9

PHOTO 10



PHOTO 11

PHOTO 12



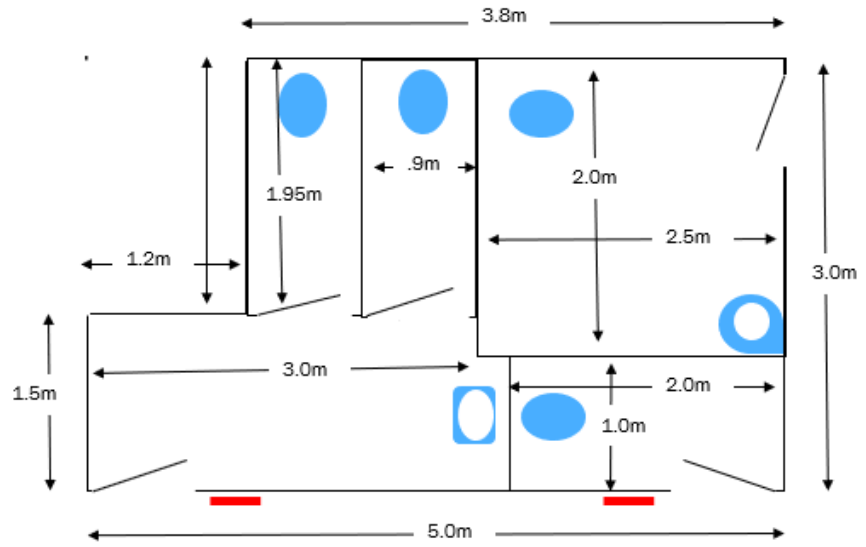

5.8.30 Pakenham Deep Creek (Asset ID 152939)



5.8.31 Pakenham Lakeside Dragon Park Exeloo (Asset ID 131169)



5.8.32 Pakenham Toomuc Rec Reserve (Asset ID 63406)

PHOTO 1



PHOTO 2



PHOTO 3



PHOTO 4



PHOTO 5

PHOTO 6

PHOTO 7



PHOTO 8

PHOTO 9

PHOTO 10



PHOTO 11

PHOTO 12

PHOTO 13



PHOTO 14

PHOTO 15



PHOTO 16



PHOTO 17



PHOTO 18



PHOTO 19



PHOTO 20



PHOTO 21



PHOTO 22



PHOTO 23



PHOTO 24



PHOTO 25



PHOTO 26



PHOTO 29



PHOTO 30



PHOTO 31



PHOTO 36



PHOTO 37



PHOTO 38



PHOTO 39



PHOTO 40



PHOTO 41

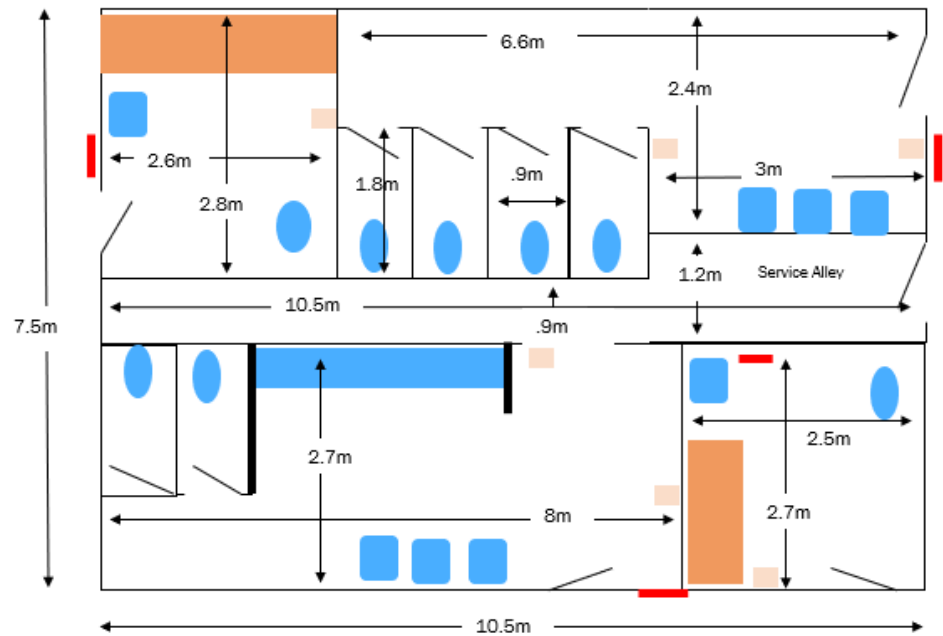

5.8.33 Pakenham Services Central (Asset ID 24540)

PHOTO 1



PHOTO 2



PHOTO 3



PHOTO 4



PHOTO 5



PHOTO 6



PHOTO 7

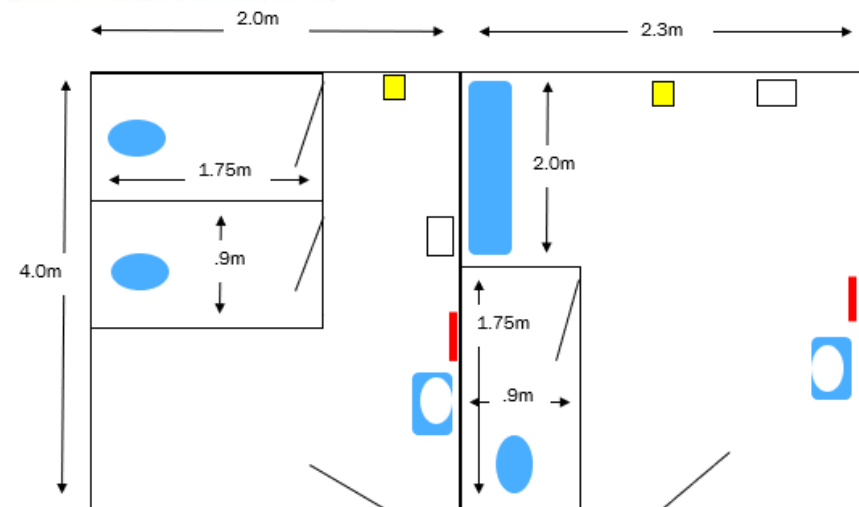

5.8.34 Pakenham Upper RJ Chambers Reserve (Asset ID 499)

PHOTO 1



PHOTO 2



PHOTO 3



PHOTO 4



PHOTO 5



PHOTO 6



PHOTO 7



PHOTO 8



PHOTO 9



PHOTO 10

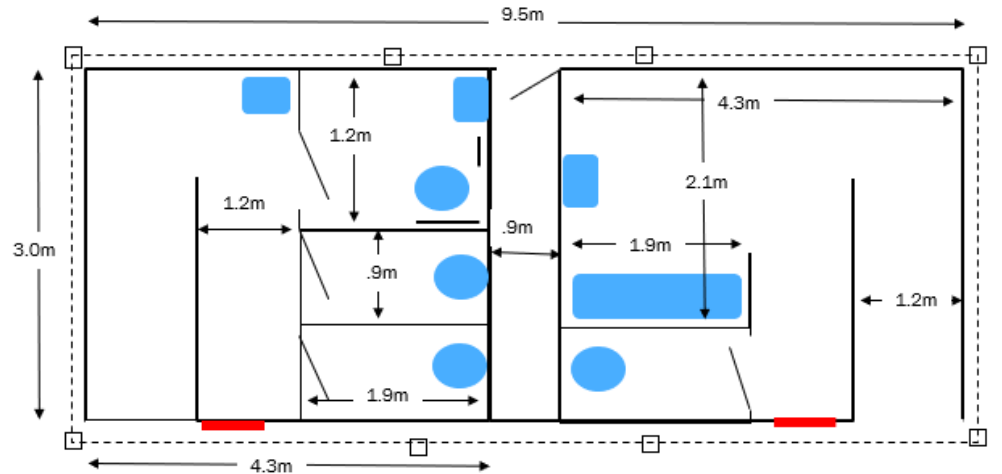

5.8.35 Tynong (Asset ID 24560)

PHOTO 1



PHOTO 2



PHOTO 3



PHOTO 4



PHOTO 5



PHOTO 6



PHOTO 7



PHOTO 8



PHOTO 9



PHOTO 10

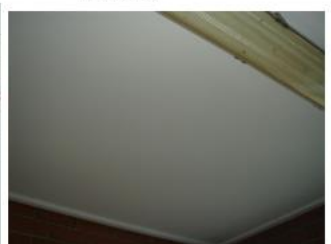

PHOTO 11



PHOTO 12

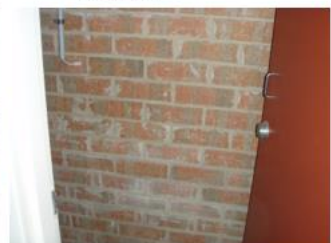

PHOTO 13



PHOTO 14



PHOTO 15



PHOTO 16

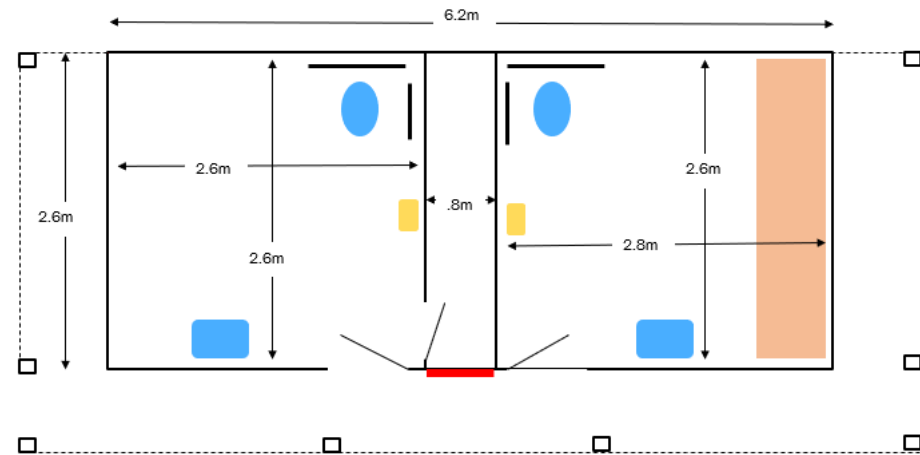

5.9 Capital Improvement Plan

A Capital Improvement Plan has been developed and is here referenced as *Attachment 1 – Capital Improvement Plan*

5.10 References

- Open Space Management Framework.
- Pedestrian & Bicycle Strategy.
- Casey Cardinia Visitation Strategy.
- Enhanced Standard – Universal Design.
- Enhanced Standard – CPTED (in development and currently as check-list).
- CCTV Policy.
- Safer Communities Strategy.
- Liveability Plan, Municipal Public Health and Wellbeing Plan.
- Council Plan.
- Access and Inclusion Policy and Action Plan.
- Age Friendly Strategy.
- National Construction Code.
- Relevant Australian Standards.
- Community Engagement Policy.
- Asset Management Policy and Strategy.
- Long Term Financial Plan.
- Enhanced Standard – Sustainable Buildings.
- Relevant Township Strategies.
- Healthy by Design Guidelines.
- Risk Management Policy and Framework.